



**SANTOSH**  
Deemed to be University



**SANTOSH**  
Academia

## Santosh Academia Solutions to JEE (Main) - 2021

Test Date: 31st August 2021 (First Shift)

### PHYSICS, CHEMISTRY & MATHEMATICS

Paper- 1

Time Allotted: 3 Hours

Maximum Marks: 300

- Please read the instructions carefully. You are allotted 5 minutes specifically for this purpose.

#### **Important Instructions:**

1. The test is of 3 hours duration.
2. This test paper consists of 90 questions. Each subject (PCM) has 30 questions. The maximum marks are 300.
3. This question paper contains **Three Parts**. **Part-A** is Physics, **Part-B** is Chemistry and **Part-C** is Mathematics. Each part has only two sections: **Section-A and Section-B**.
4. **Section – A** : Attempt all questions.
5. **Section – B** : Do any 5 questions out of 10 Questions.
6. **Section-A (01 – 20)** contains 20 multiple choice questions which have **only one correct answer**. Each question carries **+4 marks** for correct answer and **-1 mark** for wrong answer.
7. **Section-B (01 – 10)** contains 10 Numerical based questions with answer as numerical value. Each question carries **+4 marks** for correct answer. There is no negative marking.

## PART – A (PHYSICS )

### SECTION - A

(One Options Correct Type)

This section contains **20 multiple choice questions**. Each question has **four choices** (A), (B), (C) and (D), out of which **ONLY ONE** option is correct.

- Q1.** Choose the correct waveform that can represent the voltage across R of the following circuit, assuming the diode is ideal one :

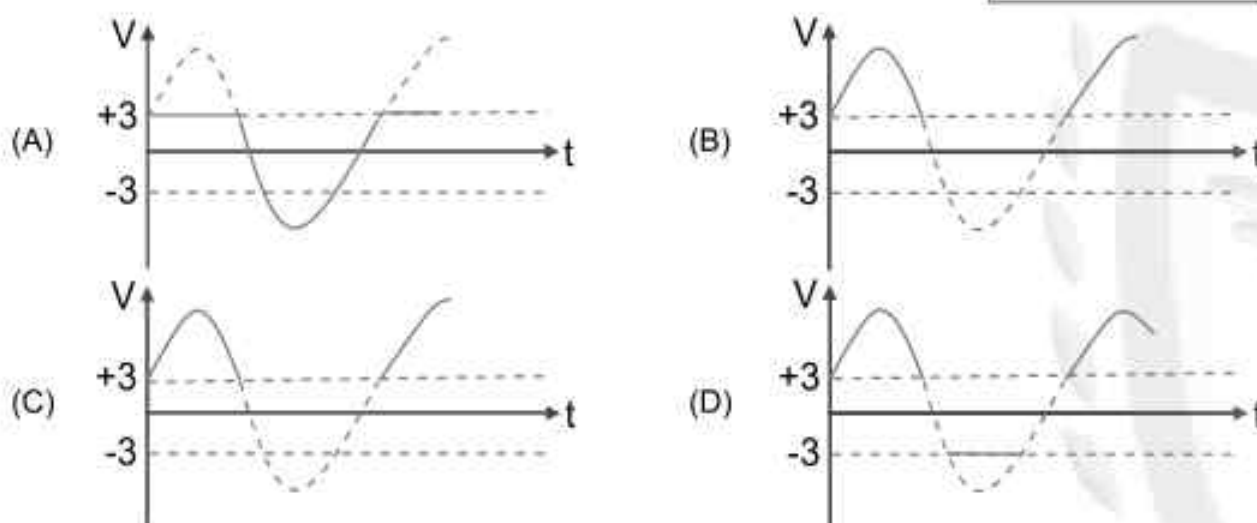
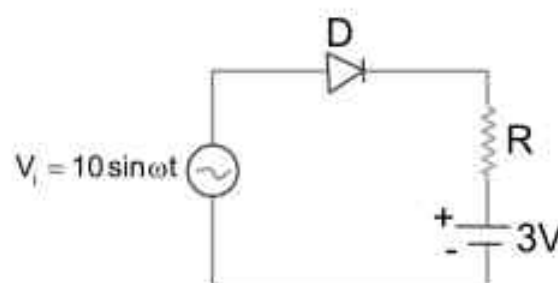

- Q2.** A coil having  $N$  turns is wound tightly in the form of a spiral with inner and outer radii 'a' and 'b' respectively. Find the magnetic field at centre, when a current  $I$  passes through coil:

(A)  $\frac{\mu_0 I}{8} \left[ \frac{a+b}{a-b} \right]$                       (B)  $\frac{\mu_0 I N}{2(b-a)} \log_e \left( \frac{b}{a} \right)$

(C)  $\frac{\mu_0 I}{4(a-b)} \left[ \frac{1}{a} - \frac{1}{b} \right]$                       (D)  $\frac{\mu_0 I}{8} \left( \frac{a-b}{a+b} \right)$

- Q3.** In an ac circuit, an inductor, a capacitor and a resistor are connected in series with  $X_L = R = X_C$ . Impedance of this circuit is:

(A)  $2R^2$     (B) Zero

(C)  $R\sqrt{2}$     (D)  $R$

- Q4.** Which of the following equations is dimensionally incorrect ?

Where  $t$  = time,  $h$  = height,  $s$  = surface tension,  $\theta$  = angle,  $\rho$  = density,  $a, r$  = radius,  $g$  = acceleration due to gravity,  $v$  = volume,  $p$  = pressure,  $W$  = work done,  $\Gamma$  = torque,  $\epsilon$  = permittivity,  $E$  = electric field,  $J$  = current density,  $L$  = length.

(A)  $W = \Gamma \theta$     (B)  $h = \frac{2s \cos \theta}{\rho g}$

(C)  $v = \frac{\pi \rho a^4}{8 \eta L}$     (D)  $J = \epsilon \frac{\partial E}{\partial t}$

- Q5.** A uniform heavy rod of weight  $10 \text{ kg ms}^{-2}$ , cross-sectional area  $100 \text{ cm}^2$  and length  $20 \text{ cm}$  is hanging from a fixed support. Young modulus of the material of the rod is  $2 \times 10^{11} \text{ Nm}^{-2}$ . Neglecting the lateral contraction, find the elongation of rod due to its own weight:

(A)  $2 \times 10^{-9} \text{ m}$  (B)  $5 \times 10^{-10} \text{ m}$   
 (C)  $4 \times 10^{-8} \text{ m}$  (D)  $5 \times 10^{-8} \text{ m}$

- Q6.** A small square loop of side 'a' and one turn is placed inside a larger square loop of side b and one turn ( $b \gg a$ ). The two loops are coplanar with their centres coinciding. If a current I is passed in the square loop of side 'b', then the coefficient of mutual inductance between the two loops is:

(A)  $\frac{\mu_0 8\sqrt{2}}{4\pi b}$  (B)  $\frac{\mu_0 8\sqrt{2} b^2}{4\pi a}$   
 (C)  $\frac{\mu_0 8\sqrt{2}}{4\pi a}$  (D)  $\frac{\mu_0 8\sqrt{2} a^2}{4\pi b}$

- Q7.** A helicopter is flying horizontally with a speed 'v' at an altitude 'h' has to drop a food packet for a man on the ground. What is the distance of helicopter from the man when the food packet is dropped?

(A)  $\sqrt{2ghv^2 + h^2}$  (B)  $\sqrt{\frac{2v^2h}{g} + h^2}$   
 (C)  $\sqrt{\frac{2gh}{v^2} + h^2}$  (D)  $\sqrt{\frac{2ghv^2 + 1}{h^2}}$

- Q8.** The masses and radii of the earth and moon are  $(M_1, R_1)$  and  $(M_2, R_2)$  respectively. Their centres are at a distance 'r' apart. Find the minimum escape velocity for a particle of mass 'm' to be projected from the middle of these two masses:

(A)  $V = \frac{1}{2} \sqrt{\frac{4G(M_1 + M_2)}{r}}$  (B)  $V = \sqrt{\frac{4G(M_1 + M_2)}{r}}$   
 (C)  $V = \frac{\sqrt{2G(M_1 + M_2)}}{r}$  (D)  $V = \frac{1}{2} \sqrt{\frac{2G(M_1 + M_2)}{r}}$

- Q9.** Two plane mirrors  $M_1$  and  $M_2$  are at right angle to each other as shown. A point source 'P' is placed at 'a' and '2a' meter away from  $M_1$  and  $M_2$  respectively. The shortest distance between the images thus formed is : (Take  $\sqrt{5} = 2.3$ )

(A)  $2\sqrt{10} a$  (B)  $2.3 a$   
 (C)  $4.6a$  (D)  $3 a$

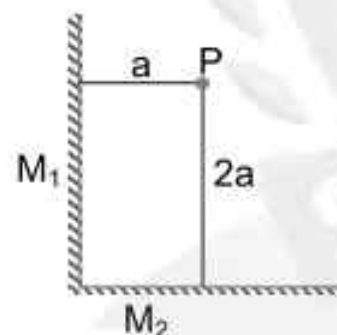

- Q10.** A reversible engine has an efficiency of  $\frac{1}{4}$ . If the temperature of the sink is reduced by  $58^\circ\text{C}$ , its efficiency becomes double. Calculate the temperature of the sink :

(A)  $280^\circ\text{C}$  (B)  $382^\circ\text{C}$   
 (C)  $180.4^\circ\text{C}$  (D)  $174^\circ\text{C}$

- Q11.** A moving proton and electron have the same de-Broglie wavelength. If K and P denote the K.E. and momentum respectively, Then choose the correct option :

(A)  $K_p = K_e$  and  $P_p = P_e$  (B)  $K_p < K_e$  and  $P_p < P_e$   
 (C)  $K_p < K_e$  and  $P_p = P_e$  (D)  $K_p > K_e$  and  $P_p = P_e$

**JEE-MAIN-2021 (31<sup>st</sup> August-First Shift)-PCM-4**

- Q12.** Consider a galvanometer shunted with  $5\Omega$  resistance and 2% of current passes through it. What is the resistance of the given galvanometer?  
 (A)  $300\Omega$  (B)  $344\Omega$   
 (C)  $226\Omega$  (D)  $245\Omega$

- Q13.** A body of mass  $M$  moving at speed  $V_0$  collides elastically with a mass ' $m$ ' at rest. After the collision, the two masses move at angles  $\theta_1$  and  $\theta_2$  with respect to the initial direction of motion of the body of mass  $M$ . The largest possible value of the ratio  $M/m$ , for which the angles  $\theta_1$  and  $\theta_2$  will be equal, is :  
 (A) 3 (B) 1  
 (C) 2 (D) 4

- Q14.** In the following logic circuit the sequence of the inputs  $A, B$  are  $(0, 0), (0, 1), (1, 0)$  and  $(1, 1)$ . The output  $Y$  for this sequence will be :  
 (A) 0, 1, 0, 1  
 (B) 1, 1, 1, 0  
 (C) 1, 0, 1, 0  
 (D) 0, 0, 1, 1

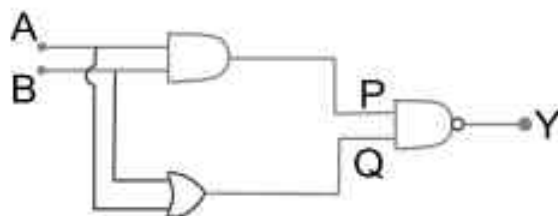

- Q15.** A sample of a radioactive nucleus  $A$  disintegrates to another radioactive nucleus  $B$ , which in turn disintegrates to some other stable nucleus  $C$ . Plot of a graph showing the variation of number of atoms of nucleus  $B$  versus time is :  
 (Assume that at  $t = 0$ , there are no  $B$  atoms in the sample)

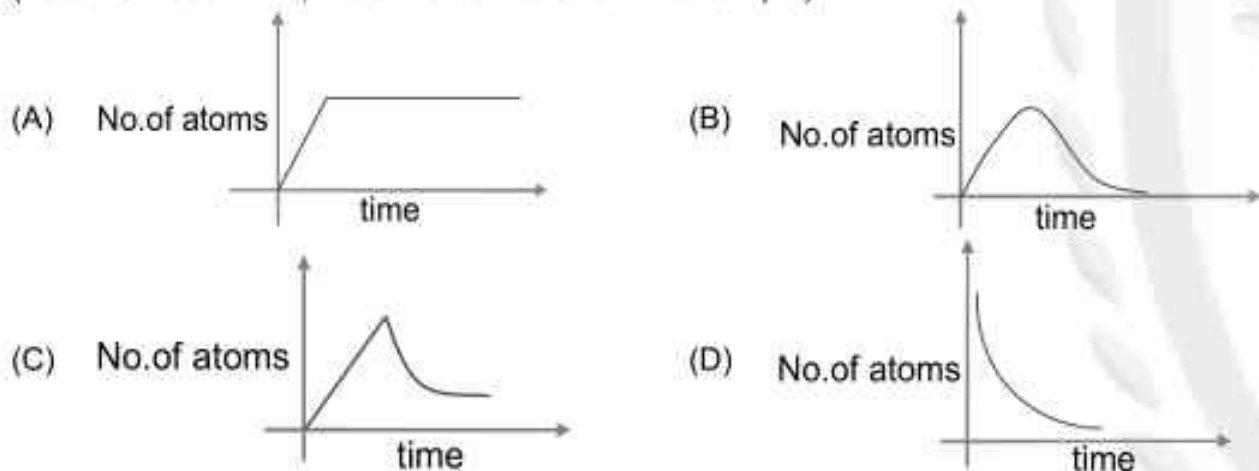

- Q16.** An object is placed at the focus of concave lens having focal length  $f$ . What is the magnification and distance of the image from the optical centre of the lens?  
 (A) Very high,  $\infty$  (B)  $\frac{1}{4}, \frac{f}{4}$   
 (C)  $\frac{1}{2}, \frac{f}{2}$  (D) 1,  $\infty$

- Q17.** For an ideal gas the instantaneous change in pressure ' $p$ ' with volume ' $v$ ' is given by the equation  $\frac{dp}{dv} = -ap$ . If  $p = p_0$  at  $v = 0$  is the given boundary condition, then the maximum temperature one mole of gas can attain is :  
 (Here  $R$  is the gas constant)

- (A)  $0^\circ\text{C}$  (B)  $\frac{ap_0}{eR}$   
 (C)  $\frac{P_0}{aeR}$  (D) infinity

- Q18.** Angular momentum of a single particle moving with constant speed along circular path :
- (A) remains same in magnitude but changes in the direction  
 (B) changes in magnitude but remains same in the direction  
 (C) remains same in magnitude and direction  
 (D) is zero

- Q19.** Match List-I with List-II.

List-I		List-II	
(a)	Torque	(i)	$MLT^{-1}$
(b)	Impulse	(ii)	$MT^{-2}$
(c)	Tension	(iii)	$ML^2T^{-2}$
(d)	Surface Tension	(iv)	$MLT^{-2}$

Choose the **most appropriate** answer from the option given below :

- (A) (a)–(ii), (b)–(i), (c)–(iv), (d)–(iii)      (B) (a)–(i), (b)–(iii), (c)–(iv), (d)–(ii)  
 (C) (a)–(iii), (b)–(i), (c)–(iv), (d)–(ii)      (D) (a)–(iii), (b)–(iv), (c)–(i), (d)–(ii)

- Q20.** Two particles A and B having charges  $20\ \mu\text{C}$  and  $-5\ \mu\text{C}$  respectively are held fixed with a separation of 5cm. At what position a third charged particle should be placed so that it does not experience a net electric force?



- (A) At 5 cm from  $20\ \mu\text{C}$  on the left side of system  
 (B) At 1.25 cm from a  $-5\ \mu\text{C}$  between two charges  
 (C) At midpoint between two charges  
 (D) At 5 cm from  $-5\ \mu\text{C}$  on the right side

## SECTION - B

(Numerical Answer Type)

This section contains **10** questions. The answer to each question is a **NUMERICAL VALUE**. For each question, enter the correct numerical value (in decimal notation, truncated/rounded-off to the **second decimal place**).

- Q1.** The voltage drop across  $15\Omega$  resistance in the given figure will be \_\_\_\_\_ V.

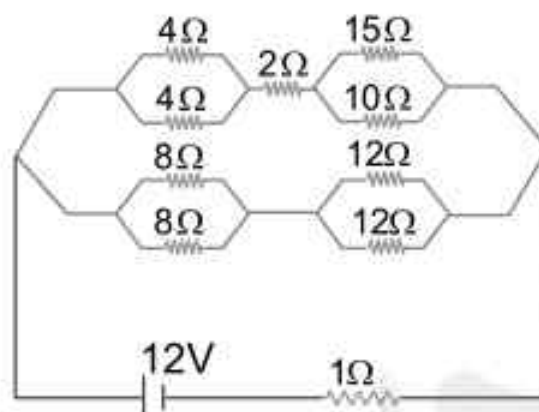

- Q2.** A square shaped wire with resistance of each side  $3\Omega$  is bent to form a complete circle. The resistance between two diametrically opposite points of the circle in unit of  $\Omega$  will be \_\_\_\_\_.
- Q3.** A car is moving on a plane inclined at  $30^\circ$  to the horizontal with an acceleration of  $10\text{ms}^{-2}$  parallel to the plane upward. A bob is suspended by a string from the roof of the car. The angle in degrees which the string makes with the vertical is \_\_\_\_\_. (Take  $g=10\text{ms}^{-2}$ )
- Q4.** A capacitor of  $50\ \mu\text{F}$  is connected in a circuit as shown in figure. The charge on the upper plate of the capacitor is \_\_\_\_\_  $\mu\text{C}$ .

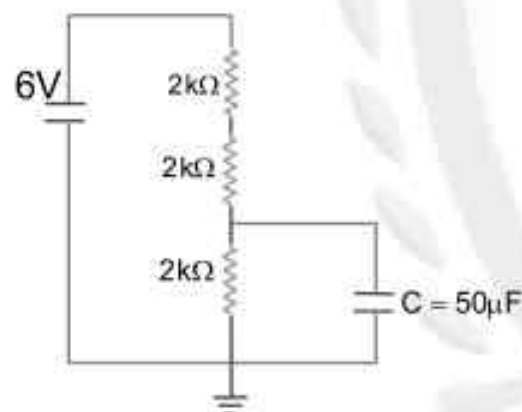

- Q5.** A wire having a linear mass density  $9.0 \times 10^{-4}\ \text{kg/m}$  is stretched between two rigid supports with a tension of 900 N. The wire resonates at a frequency of 500 Hz. The next higher frequency at which the same wire resonates is 550 Hz. The length of the wire is \_\_\_\_\_ m.
- Q6.** When a rubber ball is taken to a depth of \_\_\_\_\_ m in deep sea, its volume decreases by 0.5%.  
 (The bulk modulus of rubber =  $9.8 \times 10^8\ \text{Nm}^{-2}$   
 Density of sea water =  $10^3\ \text{kgm}^{-3}$   
 $g = 9.8\ \text{m/s}^2$ )
- Q7.** A particle of mass 1 kg is hanging from a spring of force constant  $100\ \text{Nm}^{-1}$ . The mass is pulled slightly downward and released so that it executes free simple harmonic motion with time period T. The time when the kinetic energy and potential energy of the system will become equal, is  $\frac{T}{x}$ . The value of x is \_\_\_\_\_.

- Q8.** A block moving horizontally on a smooth surface with a speed of  $40 \text{ ms}^{-1}$  splits into two equal parts. If one of the parts moves at  $60 \text{ ms}^{-1}$  in the same direction, then the fractional change in the kinetic energy will be  $x : 4$  where  $x = \underline{\hspace{2cm}}$ .
- Q9.** The electric field in an electromagnetic wave is given by  $E = (50 \text{ NC}^{-1}) \sin \omega(t - x/c)$   
The energy contained in a cylinder of volume  $V$  is  $5.5 \times 10^{-12} \text{ J}$ . The value of  $V$  is  $\underline{\hspace{2cm}} \text{ cm}^3$ .  
(given by  $\epsilon_0 = 8.8 \times 10^{-12} \text{ C}^2\text{N}^{-1}\text{m}^{-2}$ )
- Q10.** If the sum of the heights of transmitting and receiving antennas in the line of sight of communication is fixed at 160 m, then the maximum range of LOS communication is  $\underline{\hspace{2cm}}$  km.  
(Take radius of Earth = 6400 km)

## PART – B (CHEMISTRY)

### SECTION - A

(One Options Correct Type)

This section contains **20 multiple choice questions**. Each question has **four choices** (A), (B), (C) and (D), out of which **ONLY ONE** option is correct.

**Q1.** Given below are two statements : one is labelled as **Assertion (A)** and the other is labelled as **Reason (R)**.

**Assertion (A)** : Metallic character decreases and non-metallic character increases on moving from left to right in a period.

**Reason (R)** : It is due to increase in ionisation enthalpy and decrease in electron gain enthalpy, when one moves from left to right in a period.

In the light of the above statements, choose the **most appropriate** answer from the options given below:

(A) **(A)** is false but **(R)** is true.

(B) Both **(A)** and **(R)** are correct and **(R)** is the correct explanation of **(A)**

(C) Both **(A)** and **(R)** are correct but **(R)** is not the correct explanation of **(A)**

(D) **(A)** is true but **(R)** is false

**Q2.** The structure of product C, formed by the following sequence of reactions is :

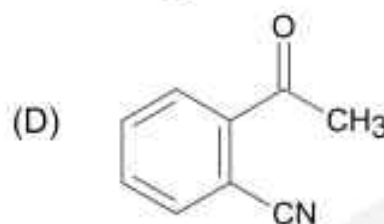
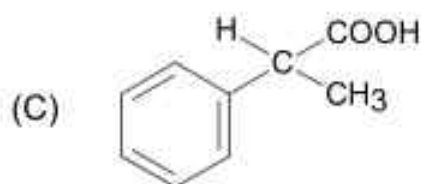
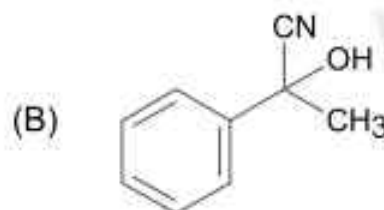
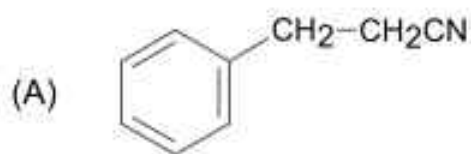
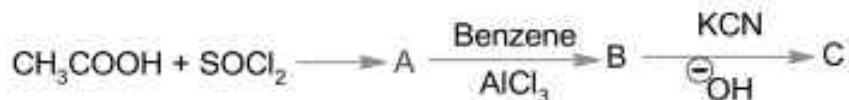

**Q3.** Given below are two statements :

**Statement-I** : The process of producing syn-gas is called gasification of coal.

**Statement-II** : The composition of syn-gas is  $\text{CO} + \text{CO}_2 + \text{H}_2$  (1 : 1 : 1)

In the light of the above statements, choose the **most appropriate** answer from the options given below :

(A) **Statement-I** is true but **Statement-II** is false

(B) Both **Statement-I** and **Statement-II** are true

(C) **Statement-I** is false but **Statement-II** is true

(D) Both **Statement-I** and **Statement-II** are false

Q4. Choose the **correct** name for compound given below :



- (A) (4E)-5-Bromo-hex-2-en-4-yne  
 (B) (2E)-2-Bromo-hex-4-yn-2-ene  
 (C) (2E)-2-Bromo-hex-2-en-4-yne  
 (D) (4E)-5-Bromo-hex-4-en-2-yne

Q5. Select the graph that correctly describes the adsorption isotherms at two temperatures  $T_1$  and  $T_2$  ( $T_1 > T_2$ ) for a gas :  
 ( $x$  – mass of the gas adsorbed ;  $m$  – mass of adsorbent ;  $P$  – pressure)

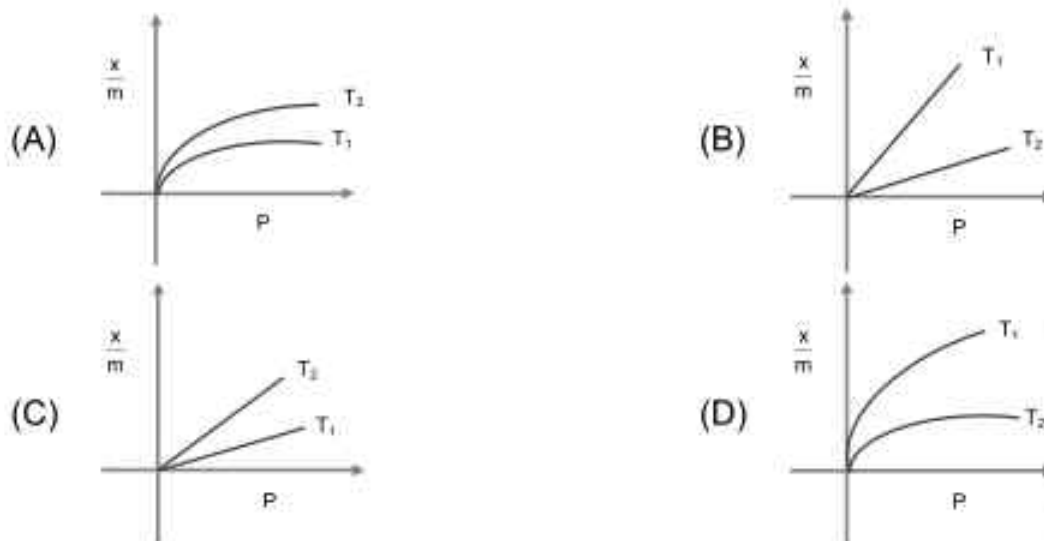

Q6. Given below are two statements: one is labelled as **Assertion (A)** and the other is labelled as **Reason (R)**.

**Assertion (A)** : Aluminium is extracted from bauxite by the electrolysis of molten mixture of  $Al_2O_3$  with cryolite.

**Reason (R)** : The oxidation state of Al in cryolite is +3.

In the light of the above statements, choose the **most appropriate** answer from the options given below :

- (A) Both (A) and (R) are correct but (R) is not the correct explanation of (A)  
 (B) Both (A) and (R) are correct and (R) is the correct explanation of (A)  
 (C) (A) is true but (R) is false  
 (D) (A) is false but (R) is true.

Q7. The major component/ingredient of Portland Cement is :

- (A) tricalcium silicate  
 (B) dicalcium aluminate  
 (C) dicalcium silicate  
 (D) tricalcium aluminate

Q8. The denticity of an organic ligand, biuret is :

- (A) 6  
 (B) 4  
 (C) 2  
 (D) 3

Q9. BOD values (in ppm) for clean water (A) and polluted water (B) are expected respectively

- (A)  $A < 5$ ,  $B > 17$   
 (B)  $A > 15$ ,  $B > 47$   
 (C)  $A > 25$ ,  $B < 17$   
 (D)  $A > 50$ ,  $B < 27$

Q10. The correct order of reactivity of the given chlorides with acetate in acetic acid is :

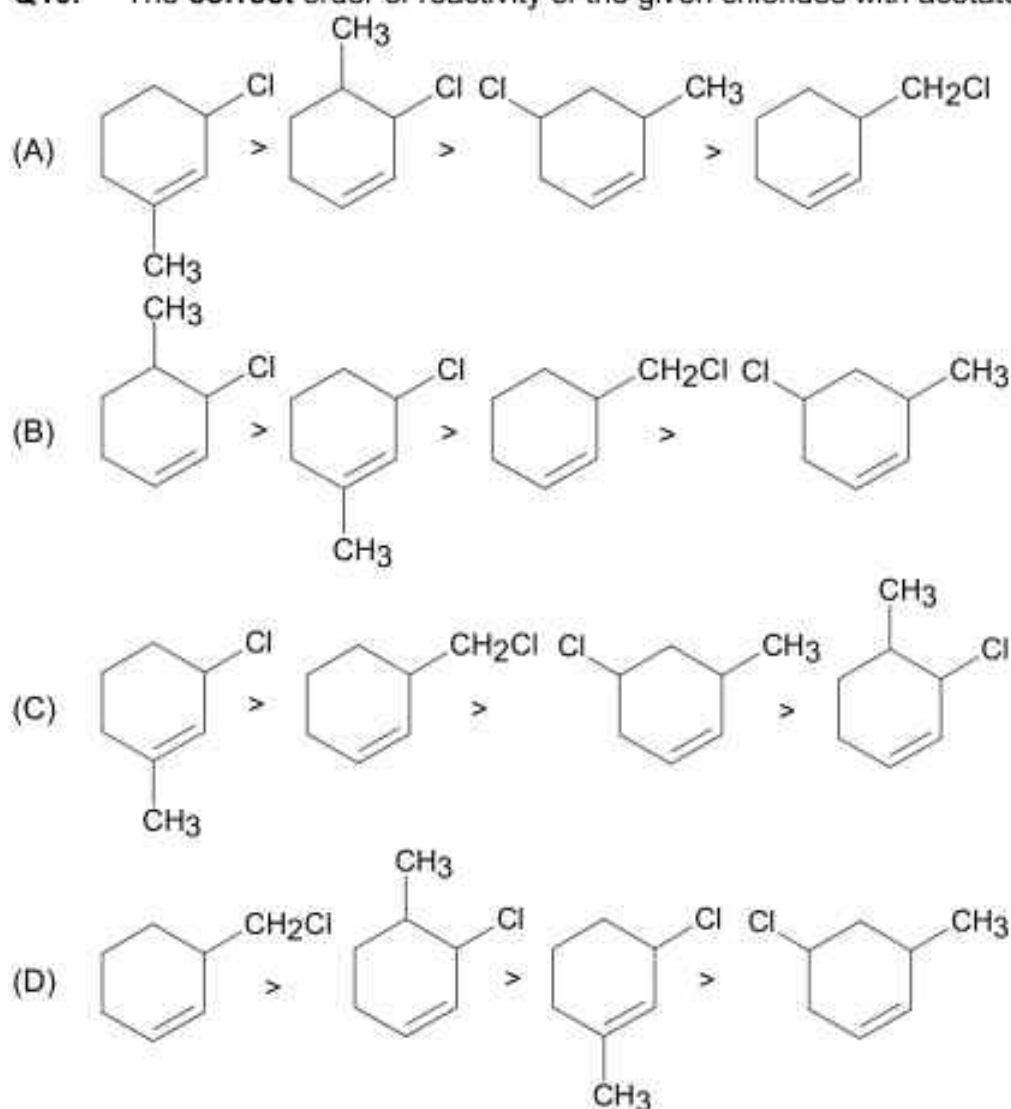

Q11. In the structure of the dichromate ion, there is a :

- (A) non-linear unsymmetrical Cr–O–Cr bond.  
 (B) non-linear symmetrical Cr–O–Cr bond.  
 (C) linear symmetrical Cr–O–Cr bond.  
 (D) linear unsymmetrical Cr–O–Cr bond.

Q12. Which one of the following lanthanides exhibits +2 oxidation state with diamagnetic nature?  
 (Given Z for Nd = 60, Yb = 70, La = 57, Ce = 58)

- (A) La (B) Yb  
 (C) Nd (D) Ce

Q13. Given below are two statements : one is labelled as **Assertion (A)** and the other is labelled as **Reason (R)** :

**Assertion (A)** : A simple distillation can be used to separate a mixture of propanol and propanone.

**Reason (R)** : Two liquids with a difference of more than 20°C in their boiling points can be separated by simple distillations.

In the light of the above statements, choose the **most appropriate** answer from the options given below :

- (A) Both (A) and (R) are correct and (R) is the correct explanation of (A)  
 (B) (A) is false but (R) is true.  
 (C) (A) is true but (R) is false  
 (D) Both (A) and (R) are correct but (R) is not the correct explanation of (A)

- Q14.** Monomer of Novolac is :  
 (A) o-Hydroxymethylphenol  
 (B) 3-Hydroxybutanoic acid  
 (C) 1,3-Butadiene and styrene  
 (D) phenol and melamine

- Q15.** Which one of the following compounds contains  $\beta$ -C<sub>1</sub>-C<sub>4</sub> glycosidic linkage?  
 (A) Maltose  
 (B) Lactose  
 (C) Amylose  
 (D) Sucrose

- Q16.** The major product formed in the following reaction is :

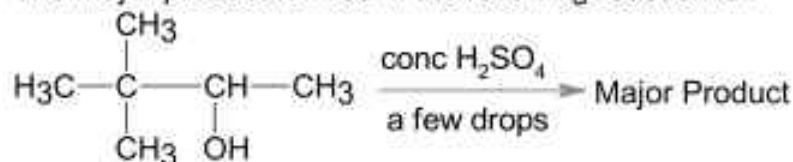

- (A)  $\text{CH}_3-\overset{\text{CH}_3}{\underset{\text{CH}_3}{\text{C}}}-\text{CH}=\text{CH}_2$   
 (B)  $\text{H}_3\text{C}-\text{C}(\text{H}_3)=\text{CH}-\text{CH}_3$   
 (C)  $\text{H}_3\text{C}-\text{C}(\text{H}_3)=\text{C}(\text{H}_3)-\text{CH}_3$   
 (D)  $\text{CH}_3-\overset{\text{CH}_3}{\text{C}}=\text{CH}-\text{CH}_2\text{CH}_3$

- Q17.** Which one of the following 0.10 M aqueous solutions will exhibit the largest freezing point depression?  
 (A) glucose  
 (B) hydrazine  
 (C) glycine  
 (D) KHSO<sub>4</sub>

- Q18.** The major products A and B in the following set of reactions are :

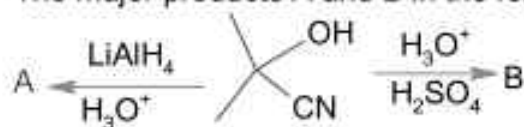

- (A) A =  $\text{C}(\text{OH})(\text{CHO})$ , B =  $\text{C}(\text{OH})(\text{CO}_2\text{H})$   
 (B) A =  $\text{C}(\text{OH})(\text{NH}_2)$ , B =  $\text{C}(\text{OH})(\text{COOH})$   
 (C) A =  $\text{C}(\text{OH})(\text{NH}_2)$ , B =  $\text{C}(\text{OH})(\text{CHO})$   
 (D) A =  $\text{C}(\text{OH})(\text{OH})$ , B =  $\text{C}(\text{OH})(\text{CHO})$

- Q19. Which one of the following is the correct PV vs P plot at constant temperature for an ideal gas? (P and V stand for pressure and volume of the gas respectively)

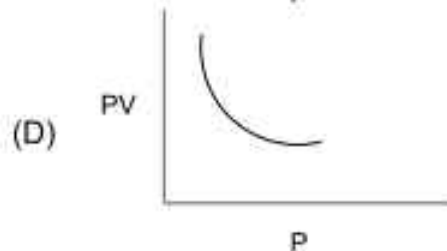
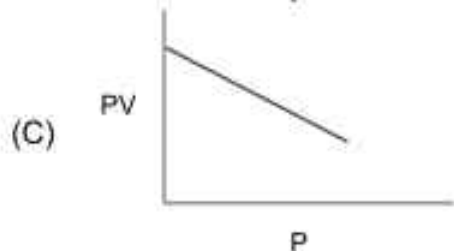
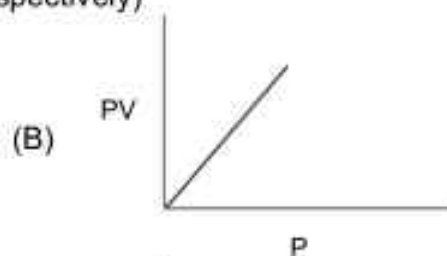
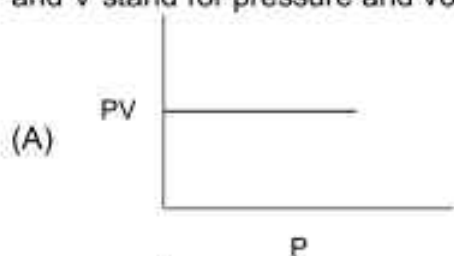

- Q20. Given below are two statements : one is labelled as **Assertion (A)** and the other is labelled as **Reason (R)**.

**Assertion (A) :** Treatment of bromine water with propene yields 1-bromopropan-2-ol.

**Reason (R) :** Attack of water on bromonium ion follows Markovnikov rule and results in 1-bromopropan-2-ol.

In the light of the above statements, choose the **most appropriate** answer from the options given below :

- (A) Both **(A)** and **(R)** are true but **(R)** is NOT the correct explanation of **(A)**  
(B) **(A)** is true but **(R)** is false.  
(C) Both **(A)** and **(R)** are true and **(R)** is the correct explanation of **(A)**  
(D) **(A)** is false but **(R)** is true.

## SECTION - B

(Numerical Answer Type)

This section contains **10** questions. The answer to each question is a **NUMERICAL VALUE**. For each question, enter the correct numerical value (in decimal notation, truncated/rounded-off to the **second decimal place**).

- Q1.**  $A_3B_2$  is a sparingly soluble salt of molar mass  $M$  ( $\text{g mol}^{-1}$ ) and solubility  $x$   $\text{g L}^{-1}$ . The solubility product satisfies  $K_{sp} = a \left( \frac{x}{M} \right)^5$ . The value of  $a$  is \_\_\_\_\_. (Integer answer)
- Q2.** The total number of reagents from those given below, that can convert nitrobenzene into aniline is \_\_\_\_\_. (Integer answer)
- I. Sn – HCl
  - II. Sn –  $\text{NH}_4\text{OH}$
  - III. Fe – HCl
  - IV. Zn – HCl
  - V.  $\text{H}_2$  – Pd
  - VI.  $\text{H}_2$  – Raney Nickel
- Q3.** The molarity of the solution prepared by dissolving 6.3 g of oxalic acid ( $\text{H}_2\text{C}_2\text{O}_4 \cdot 2\text{H}_2\text{O}$ ) in 250 mL of water in  $\text{mol L}^{-1}$  is  $x \times 10^{-2}$ . The value of  $x$  is \_\_\_\_\_. (Nearest integer)  
[Atomic mass : H : 1.0, C : 12.0, O : 16.0]
- Q4.** Consider the following cell reaction :
- $$\text{Cd}_{(s)} + \text{Hg}_2\text{SO}_{4(s)} + \frac{9}{5}\text{H}_2\text{O}_{(l)} + \text{CdSO}_4 \cdot \frac{9}{5}\text{H}_2\text{O}_{(s)} + 2\text{Hg}_{(l)}$$
- The value of  $E_{\text{cell}}^{\circ}$  is 4.315V at 25°C. If  $\Delta H^{\circ} = -825.2 \text{ kJ mol}^{-1}$ , the standard entropy change  $\Delta S^{\circ}$  in  $\text{J K}^{-1}$  is \_\_\_\_\_. (Nearest integer)  
[Given: Faraday constant =  $96487 \text{ C mol}^{-1}$ ]
- Q5.** Consider the sulphides HgS, PbS, CuS,  $\text{Sb}_2\text{S}_3$ ,  $\text{As}_2\text{S}_3$  and CdS. Number of these sulphides soluble in 50%  $\text{HNO}_3$  is \_\_\_\_\_.
- Q6.** For a first order reaction, the ratio of the time for 75% completion of a reaction to the time for 50% completion is \_\_\_\_\_. (Integer answer)
- Q7.** According to the following figure, the magnitude of the enthalpy change of the reaction  $A + B \rightarrow M + N$  in  $\text{kJ mol}^{-1}$  is equal to \_\_\_\_\_. (Integer answer)

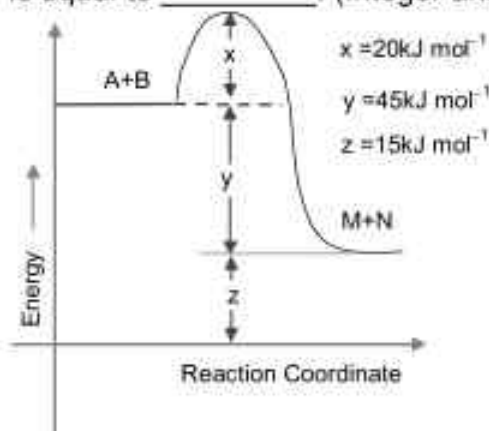

**JEE-MAIN-2021 (31<sup>st</sup> August-First Shift)-PCM-14**

- Q8.** The number of halogen/(s) forming halic (V) acid is \_\_\_\_\_.
- Q9.** The number of hydrogen bonded water molecule(s) associated with stoichiometry  $\text{CuSO}_4 \cdot 5\text{H}_2\text{O}$  is \_\_\_\_\_.
- Q10.**  $\text{Ge}(Z = 32)$  in its ground state electronic configuration has  $x$  completely filled orbitals with  $m_l = 0$ . The value of  $x$  is \_\_\_\_\_.



**PART – C (MATHEMATICS )****SECTION - A****(One Options Correct Type)**

This section contains **20 multiple choice questions**. Each question has **four choices** (A), (B), (C) and (D), out of which **ONLY ONE** option is correct.

- Q1.** Let  $*, \square \in \{\wedge, \vee\}$  be such that the Boolean expression  $(p* \sim q) \Rightarrow (p \square q)$  is a tautology. Then :
- (A)  $* = \wedge, \square = \vee$  (B)  $* = \wedge, \square = \wedge$   
 (C)  $* = \vee, \square = \wedge$  (D)  $* = \vee, \square = \vee$
- Q2.** Let the equation of the plane, that passes through the point  $(1, 4, -3)$  and contains the line of intersection of the planes  $3x - 2y + 4z - 7 = 0$  and  $x + 5y - 2z + 9 = 0$ , be  $\alpha x + \beta y + \gamma z + 3 = 0$ , then  $\alpha + \beta + \gamma$  is equal to:
- (A) 23 (B) 15  
 (C) -15 (D) -23
- Q3.** The number of real roots of the equation  $e^{4x} + 2e^{3x} - e^x - 6 = 0$  is:
- (A) 4 (B) 0  
 (C) 1 (D) 2
- Q4.** The function  $f(x) = |x^2 - 2x - 3| \cdot e^{9x^2 - 12x + 4}$  is not differentiable at exactly:
- (A) three points (B) four points  
 (C) two points (D) one point
- Q5.** If  $p$  and  $q$  are the lengths of the perpendiculars from the origin on the lines  $x \operatorname{cosec} \alpha - y \sec \alpha = k \cot 2\alpha$  and  $x \sin \alpha + y \cos \alpha = k \sin 2\alpha$  respectively, then  $k^2$  is equal to:
- (A)  $p^2 + 2q^2$  (B)  $4p^2 + q^2$   
 (C)  $p^2 + 4q^2$  (D)  $2p^2 + q^2$
- Q6.**  $\lim_{x \rightarrow 0} \frac{\sin^2(\pi \cos^4 x)}{x^4}$  is equal to:
- (A)  $2\pi^2$  (B)  $4\pi^2$   
 (C)  $\pi^2$  (D)  $4\pi$
- Q7.** If  $a_r = \cos \frac{2r\pi}{9} + i \sin \frac{2r\pi}{9}, r = 1, 2, 3, \dots, i = \sqrt{-1}$ , then the determinant  $\begin{vmatrix} a_1 & a_2 & a_3 \\ a_4 & a_5 & a_6 \\ a_7 & a_8 & a_9 \end{vmatrix}$  is equal to:
- (A)  $a_2 a_6 - a_4 a_8$  (B)  $a_9$   
 (C)  $a_1 a_9 - a_3 a_7$  (D)  $a_5$
- Q8.** The length of the latus rectum of a parabola, whose vertex and focus are on the positive x-axis at a distance  $R$  and  $S (>R)$  respectively from the origin, is :
- (A)  $4(S + R)$  (B)  $2(S + R)$   
 (C)  $2(S - R)$  (D)  $4(S - R)$

**JEE-MAIN-2021 (31<sup>st</sup> August-First Shift)-PCM-16**

**Q9.** Three numbers are in an increasing geometric progression with common ratio  $r$ . If the middle number is doubled, then the new numbers are in an arithmetic progression with common difference  $d$ . If the fourth term of GP is  $3r^2$ , then  $r^2 - d$  is equal to:

- (A)  $7 + \sqrt{3}$  (B)  $7 - \sqrt{3}$   
 (C)  $7 + 3\sqrt{3}$  (D)  $7 - 7\sqrt{3}$

**Q10.** The line  $12x \cos\theta + 5y \sin\theta = 60$  is tangent to which of the following curves?

- (A)  $144x^2 + 25y^2 = 3600$  (B)  $x^2 + y^2 = 60$   
 (C)  $x^2 + y^2 = 169$  (D)  $25x^2 + 12y^2 = 3600$

**Q11.** If the function  $f(x) = \begin{cases} \frac{1}{x} \log_x \left( \frac{1+\frac{x}{a}}{1-\frac{x}{b}} \right), & x < 0 \\ k, & x = 0 \\ \frac{\cos^2 x - \sin^2 x - 1}{\sqrt{x^2 + 1} - 1}, & x > 0 \end{cases}$

is continuous at  $x = 0$ , then  $\frac{1}{a} + \frac{1}{b} + \frac{4}{k}$  is equal to:

- (A) 4 (B) -5  
 (C) 5 (D) -4

**Q12.** The integral  $\int \frac{1}{\sqrt[4]{(x-1)^3(x+2)^5}} dx$  is equal to: (where  $C$  is a constant of integration)

- (A)  $\frac{4}{3} \left( \frac{x-1}{x+2} \right)^{\frac{5}{4}} + C$  (B)  $\frac{3}{4} \left( \frac{x+2}{x-1} \right)^{\frac{5}{4}} + C$   
 (C)  $\frac{4}{3} \left( \frac{x-1}{x+2} \right)^{\frac{1}{4}} + C$  (D)  $\frac{3}{4} \left( \frac{x+2}{x-1} \right)^{\frac{1}{4}} + C$

**Q13.** The sum of 10 terms of the series

$$\frac{3}{1^2 \times 2^2} + \frac{5}{2^2 \times 3^2} + \frac{7}{3^2 \times 4^2} + \dots \text{ is:}$$

- (A)  $\frac{143}{144}$  (B) 1  
 (C)  $\frac{99}{100}$  (D)  $\frac{120}{121}$

**Q14.** Which of the following is **not** correct for relation  $R$  on the set of real numbers?

- (A)  $(x, y) \in R \Leftrightarrow 0 < |x| - |y| \leq 1$  is neither transitive nor symmetric.  
 (A)  $(x, y) \in R \Leftrightarrow < |x - y| \leq 1$  is reflexive and symmetric.  
 (C)  $(x, y) \in R \Leftrightarrow < |x| - |y| \leq 1$  is reflexive but not symmetric.  
 (D)  $(x, y) \in R \Leftrightarrow 0 < |x - y| \leq 1$  is symmetric and transitive.

- Q15.** If  $\frac{dy}{dx} = \frac{2^{x+y} - 2^x}{2^y}$ ,  $y(0) = 1$ , then  $y(1)$  is equal to:  
 (A)  $\log_2(1 + e)$  (B)  $\log_2(1 + e^2)$   
 (C)  $\log_2(2 + e)$  (D)  $\log_2(2e)$
- Q16.** Let  $f$  be a non-negative function in  $[0, 1]$  and twice differentiable in  $(0, 1)$ . If  $\int_0^x \sqrt{1 - (f(t))^2} dt = \int_0^x f(t) dt$ ,  $0 \leq x \leq 1$  and  $f(0) = 0$ , then  $\lim_{x \rightarrow 0} \frac{1}{x^2} \int_0^x f(t) dt$ :  
 (A) does not exist (B) equals 1  
 (C) equals  $\frac{1}{2}$  (D) equals 0
- Q17.** Let  $\vec{a}$  and  $\vec{b}$  be two vectors such that  $|2\vec{a} + 3\vec{b}| = |3\vec{a} + \vec{b}|$  and the angle between  $\vec{a}$  and  $\vec{b}$  is  $60^\circ$ . If  $\frac{1}{8}\vec{a}$  is a unit vector, then  $|\vec{b}|$  is equal to:  
 (A) 6 (B) 5  
 (C) 8 (D) 4
- Q18.**  $\operatorname{cosec} 18^\circ$  is a root of the equation:  
 (A)  $x^2 + 2x - 4 = 0$  (B)  $x^2 - 2x + 4 = 0$   
 (C)  $4x^2 + 2x - 1 = 0$  (D)  $x^2 - 2x - 4 = 0$
- Q19.** A vertical pole fixed to the horizontal ground is divided in the ratio 3 : 7 by a mark on it with lower part shorter than the upper part. If the two parts subtend equal angles at a point on the ground 18 m away from the base of the pole, then the height of the pole (in meters) is :  
 (A)  $8\sqrt{10}$  (B)  $12\sqrt{15}$   
 (C)  $12\sqrt{10}$  (D)  $6\sqrt{10}$
- Q20.** If the following system of linear equations  
 $2x + y + z = 5$   
 $x - y + z = 3$   
 $x + y + az = b$   
 has no solution, then:  
 (A)  $a \neq -\frac{1}{3}, b = \frac{7}{3}$  (B)  $a = \frac{1}{3}, b = \frac{7}{3}$   
 (C)  $a = \frac{1}{3}, b \neq \frac{7}{3}$  (D)  $a = -\frac{1}{3}, b \neq \frac{7}{3}$

## SECTION - B

(Numerical Answer Type)

This section contains **10** questions. The answer to each question is a **NUMERICAL VALUE**. For each question, enter the correct numerical value (in decimal notation, truncated/rounded-off to the **second decimal place**).

- Q1.** If 'R' is the least value of 'a' such that the function  $f(x) = x^2 + ax + 1$  is increasing on  $[1, 2]$  and 'S' is the greatest value of 'a' such that the function  $f(x) = x^2 + ax + 1$  is decreasing on  $[1, 2]$ , then the value of  $|R - S|$  is \_\_\_\_\_.
- Q2.** Let  $[t]$  denote the greatest integer  $\leq t$ . Then the value of  $8 \cdot \int_{-\frac{1}{2}}^1 ([2x] + |x|) dx$  is \_\_\_\_\_.
- Q3.** If the variable line  $3x + 4y = \alpha$  lies between the two circles  $(x-1)^2 + (y-1)^2 = 1$  and  $(x-9)^2 + (y-1)^2 = 4$ , without intercepting a chord on either circle, then the sum of all the integral values of  $\alpha$  is \_\_\_\_\_.
- Q4.** The number of six letter words (with or without meaning), formed using all the letters of the word 'VOWELS', so that all the consonants never come together, is \_\_\_\_\_.
- Q5.** The square of the distance of the point of intersection of the line  $\frac{x-1}{2} = \frac{y-2}{3} = \frac{z+1}{6}$  and the plane  $2x - y + z = 6$  from the point  $(-1, -1, 2)$  is \_\_\_\_\_.
- Q6.** If  $\left(\frac{3^6}{4^4}\right)^k$  is the term, independent of  $x$ , in the binomial expansion of  $\left(\frac{x}{4} - \frac{12}{x^2}\right)^{12}$ , then  $k$  is equal to \_\_\_\_\_.
- Q7.** A point  $z$  moves in the complex plane such that  $\arg\left(\frac{z-2}{z+2}\right) = \frac{\pi}{4}$ , then the minimum value of  $|z - 9\sqrt{2} - 2i|^2$  is equal to \_\_\_\_\_.
- Q8.** The mean of 10 numbers  $7 \times 8, 10 \times 10, 13 \times 12, 16 \times 14, \dots$  is \_\_\_\_\_.
- Q9.** An electric instrument consists of two units. Each unit must function independently for the instrument to operate. The probability that the first unit functions is 0.9 and that of the second unit is 0.8. The instrument is switched on and it fails to operate. If the probability that only the first unit failed and second unit is functioning is  $p$ , then  $98p$  is equal to \_\_\_\_\_.
- Q10.** If  $x \phi(x) = \int_5^x (3t^2 - 2\phi'(t)) dt, x > -2$ , and  $\phi(0) = 4$ , then  $\phi(2)$  is \_\_\_\_\_.

# Santosh Academia

## Keys to JEE (Main) - 2021

### PART – A (PHYSICS)

#### SECTION - A

1.	B	2.	B	3.	D	4.	C
5.	B	6.	D	7.	B	8.	B
9.	C	10.	D	11.	C	12.	D
13.	A	14.	B	15.	B	16.	C
17.	C	18.	C	19.	C	20.	D

#### SECTION - B

1.	6	2.	3	3.	30	4.	100
5.	10	6.	500	7.	8	8.	1
9.	500	10.	64				

### PART – B (CHEMISTRY)

#### SECTION - A

1.	D	2.	B	3.	A	4.	C
5.	A	6.	A	7.	A	8.	C
9.	A	10.	A	11.	B	12.	B
13.	A	14.	A	15.	B	16.	C
17.	D	18.	B	19.	A	20.	C

#### SECTION - B

1.	108	2.	5	3.	20	4.	25
5.	4	6.	2	7.	45	8.	3
9.	1	10.	7				

## **PART – C (MATHEMATICS)**

### **SECTION - A**

1.	A	2.	D	3.	C	4.	C
5.	B	6.	B	7.	C	8.	D
9.	A	10.	A	11.	B	12.	C
13.	D	14.	D	15.	A	16.	C
17.	B	18.	D	19.	C	20.	C

### **SECTION – B**

1.	2	2.	5	3.	165	4.	576
5.	61	6.	55	7.	98	8.	398
9.	28	10.	4				

# Santosh Academia

## Solutions to JEE (Main) - 2021

### PART – A (PHYSICS)

#### SECTION – A

- Sol1.** Diode, in forward biased condition only, will allow current to flow through it.  
Pot. diff across resistor is  
 $\Delta V = (10 \sin \omega t - 3)$  volt  
But in reverse biased condition of diode,  
 $\Delta V = 0$  (across diode)

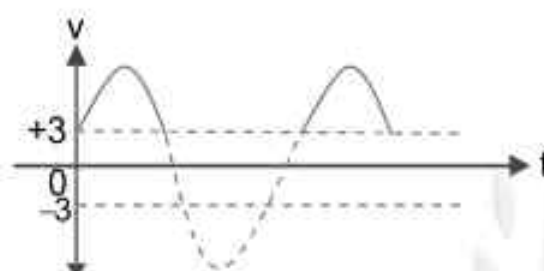

- Sol2.** Let us consider an elementary ring of radius  $r$  and thickness  $dr$  in which current is flowing.  
So, No. of turns in this elementary ring

$$dN = \left( \frac{N}{b-a} \right) dr$$

$$\therefore (dB)_{\text{at centre}} = \frac{\mu_0 I dN}{2r}$$

$$\text{or } B = \int dB = \int_a^b \frac{\mu_0 I}{2r} \times \left( \frac{N}{b-a} \right) dr$$

$$\text{or } B = \frac{\mu_0 I N}{2(b-a)} \ln \frac{b}{a}$$

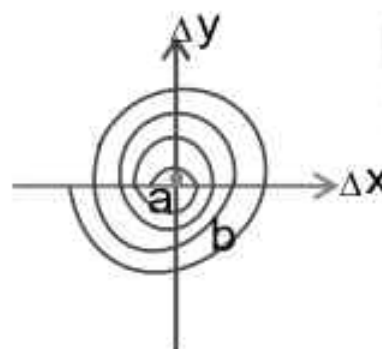

- Sol3.**  $Z = \sqrt{R^2 + (X_c - X_L)^2}$   
 $Z = \sqrt{R^2 + (R - R)^2} \quad [\because X_L = X_c = R \rightarrow \text{Given}]$   
 $Z = R$

- Sol4.**  $\rightarrow [W] = [\tau\theta] = [ML^2T^{-2}] \rightarrow \text{correct}$   
 $\rightarrow [h] = [L] = \left[ \frac{2s \cos \theta}{\rho r g} \right] \rightarrow \text{correct}$   
 $\rightarrow [v] = [L^3]; \left[ \frac{\pi \rho a^4}{8 \eta L} \right] = [L^3 T^{-1}] \rightarrow \text{Incorrect}$   
 $\rightarrow J = \epsilon \frac{\partial E}{\partial t} \rightarrow \text{correct}$   
 $[AL^{-2}] [AL^{-2}]$

Sol5.  $W = 10 \text{ kg m / s}^2$

$$A = 100 \text{ cm}^2$$

$$\ell = 20 \text{ cm}$$

$$Y = 2 \times 10^{11} \text{ N / m}^2$$

$$Y = \frac{F\ell}{A\Delta\ell} \Rightarrow \Delta\ell = \frac{F\ell}{AY}$$

For elemental mass of length,  $dx$

Change in its length

$$d(\Delta\ell) = \frac{\frac{w}{\ell}(\ell-x) \cdot dx}{AY}$$

$$\therefore \Delta\ell = \int d(\Delta\ell)$$

$$= \int_0^\ell \frac{w}{A\ell y}(\ell-x) dx$$

$$\Delta\ell = \frac{1}{2} \frac{w\ell}{AY}$$

On putting values we get

$$\Delta\ell = 5 \times 10^{-10} \text{ m}$$

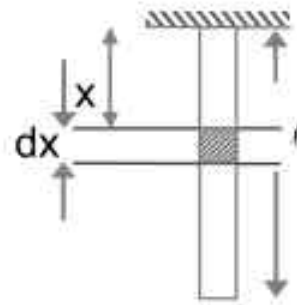

Sol6.  $\phi = MI$

Also

$$\phi = \vec{B} \cdot \vec{A} = BA \cos 0^\circ$$

$$= 4 \left\{ \frac{\mu_0 I}{4\pi \left(\frac{b}{2}\right)} \left[ \frac{1}{\sqrt{2}} + \frac{1}{\sqrt{2}} \right] \right\} \cdot a^2$$

$$\phi = 4 \times \frac{\mu_0 I}{2\pi b} \sqrt{2} a^2$$

And on comparing  $\phi$  with

$$\phi = MI$$

$$4 \times \frac{\mu_0 I \sqrt{2} a^2}{2\pi b} = MI$$

$$\frac{\mu_0}{4\pi} 8\sqrt{2} \frac{a^2}{b} = M$$

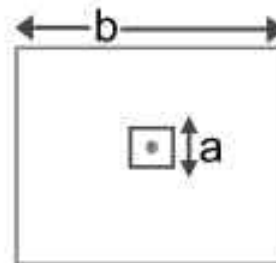

Sol7.  $h = \frac{1}{2} gt^2$

$$\text{or } t = \sqrt{\frac{2h}{g}}$$

$$\text{So, } x = vt$$

$$\text{or, } x = v \sqrt{\frac{2h}{g}}$$

So, dist of man from helicopter is

$$\sqrt{h^2 + x^2} = \sqrt{h^2 + v^2 \frac{2h}{g}} = \sqrt{\frac{2v^2 h}{g} + h^2}$$

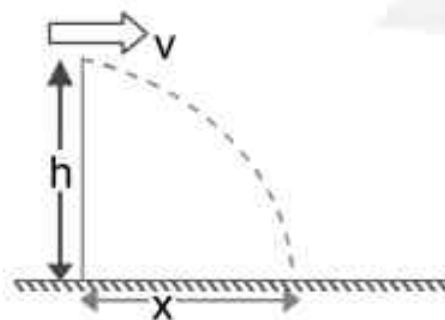

**Sol8.** at point P,  
 $= KE_p + PE_p$   
 $= \frac{1}{2}mv_p^2 + \left\{ \frac{-GM_1m}{(r/2)} - \frac{GM_2m}{r/2} \right\}$   
 at infinity (ie for escaping from both masses)  
 $= KE_\infty + PE_\infty$   
 $= 0 + 0$

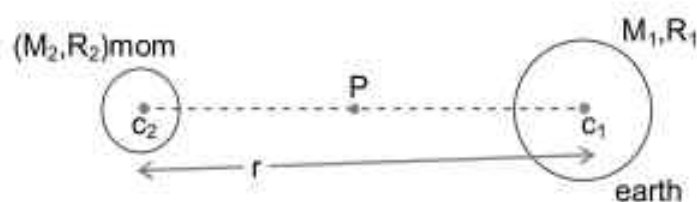

So, According to conservation of mechanical energy  
 $KE_p + PE_p = KE_\infty + PE_\infty$   
 $\Rightarrow \frac{1}{2}mv_p^2 - \frac{2Gm}{r}(M_1 + M_2) = 0 + 0$   
 $\Rightarrow v_p = \sqrt{\frac{4G(M_1 + M_2)}{r}}$

**Sol9.** dist  $l_1, l_2 = 2\sqrt{5}a$   
 $= 2 \times 2.3a$   
 $= 4.6a$

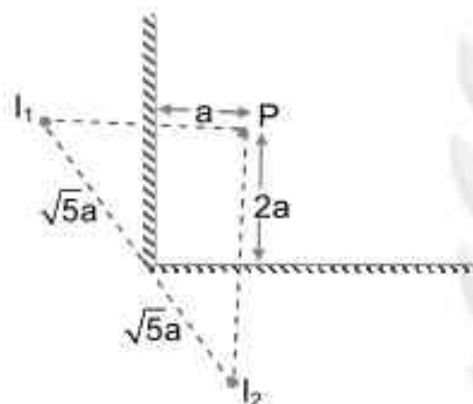

**Sol10.**  $\eta = \frac{1}{4}$  or 25%  
 $\Delta T_{\text{sink}} = -58^\circ\text{C}$  (ie decreased)  
 $\eta' = \frac{1}{2}$  or 50%  
 $T_{\text{sink}} = ?$

As we know, the efficiency for a reversible engine is given by :

$$\eta = 1 - \frac{T_2}{T_1} \quad [T_2 \rightarrow \text{sink temperature}]$$

$$\frac{1}{4} = 1 - \frac{T_2}{T_1} \quad \& \quad \frac{1}{2} = 1 - \frac{(T_2 - 58^\circ)}{T_1}$$

On comparing both, we get

$$T_2 = \frac{3}{4}T_1 \quad \& \quad (T_2 - 58^\circ\text{C}) = \frac{T_1}{2}$$

$$\frac{T_2}{T_2 - 58^\circ\text{C}} = \frac{\frac{3}{4}T_1}{\frac{T_1}{2}} \Rightarrow T_2 = 174^\circ\text{C}$$

<b>Sol11.</b>	<b>Proton</b>	<b>electron</b>
Charge :	+e	-e
Wavelength :	$\lambda$	$\lambda$
KE :	$K_p$	$K_e$
Momentum :	$P_p$	$P_e$

As we know  $KE = \frac{P^2}{2m}$

Also, de-broglie wavelength,  $\lambda$  is given by

$$\lambda = \frac{h}{p} \quad \text{or} \quad \lambda = \frac{h}{\sqrt{2mK}}$$

$\therefore \lambda \rightarrow$  same for both

$$\therefore K_p < K_e$$

Again  $\lambda = \frac{h}{p}$

$\therefore p \rightarrow$  same for both

$$\therefore P_p = P_e$$

**Sol12.**  $\Rightarrow 0.02i \times R_G = 0.98i \times 5$   
 [in parallel, pot. Diff is same]  
 or,  $R_G = 49 \times 5$   
 $R_G = 245 \Omega$

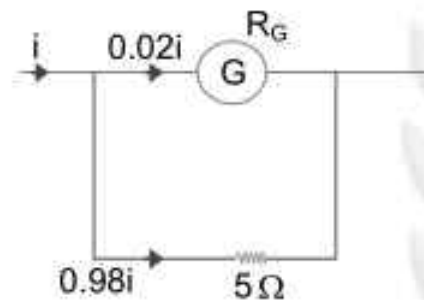

**Sol13.**  $MV_0 = MV_1 + mV_2 \quad \dots(i)$   
 also,  $\theta_1 = \theta_2 = \theta$  (say)  
 $\therefore MV_1 = mV_2 \quad \dots(ii)$   
 $\frac{1}{2}MV_0^2 = \frac{1}{2}MV_1^2 + \frac{1}{2}mV_2^2$   
 $MV_0^2 = MV_1^2 + mV_2^2 \quad \dots(iii)$   
 $MV_0^2 = MV_1^2 + m\left(\frac{MV_1}{m}\right)^2$  [using eq<sup>n</sup> (ii)]  
 $MV_0^2 = \left(M + \frac{M^2}{m}\right)V_1^2$   
 $V_0^2 = \left(1 + \frac{M}{m}\right)V_1^2$   
 $(MV_0)^2 = (MV_1)^2 + (mV_2)^2 + 2(MV_1)(mV_2)\cos(180 - 2\alpha)$   
 $(MV_0)^2 = 2(MV_1)^2 + 2(MV_1)^2 \cos \alpha$  [using eq<sup>n</sup> (ii)]  
 $(MV_0)^2 = 2(MV_1)^2 [1 + \cos \alpha]$   
 $V_0^2 = 2V_1^2 (1 + \cos \alpha)$   
 $V_0^2 = \left(1 + \frac{M}{m}\right)V_1^2 = 2V_1^2 (1 + \cos \alpha) \left(1 + \frac{M}{m}\right) = 2(1 + \cos \alpha)$   
 $(\cos \alpha)_{\max} = 1$

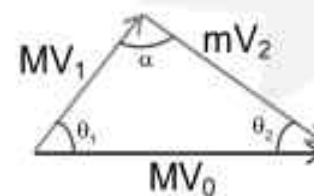
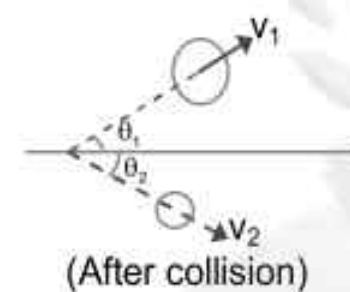
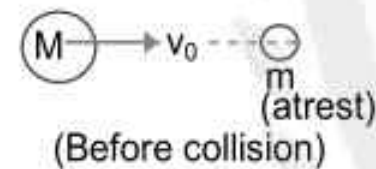

$$\left(1 + \frac{M}{m}\right) = 4$$

$$\left(\frac{M}{m}\right)_{\max} = 3$$

Sol14. Input are :

(0,0);(0,1);(1,0);(1,1).

Thus, the output y is : (1,1,1,0) s

A	B	P	Q	Y
0	0	0	0	1
0	1	0	1	1
1	0	0	1	1
1	1	1	1	0

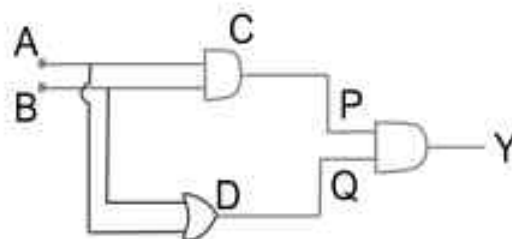

Sol15.  $A \xrightarrow{\lambda_A} B \xrightarrow{\lambda_B} C$

Amount of B,

$$N_B = \frac{\lambda_A N_{A_0}}{\lambda_B - \lambda_A} [e^{-\lambda_A t} - e^{-\lambda_B t}]$$

$$\text{or } N_B = K(e^{-\lambda_A t} - e^{-\lambda_B t})$$

$$\text{Where } K = \frac{\lambda_A}{\lambda_B - \lambda_A} N_{A_0}$$

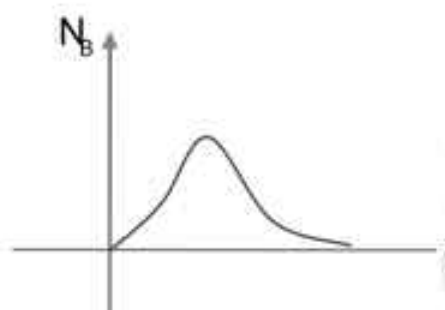

Sol16.  $m = \frac{f}{f+u} = \frac{-f}{-f-f} = +\frac{1}{2}$

$$v = \frac{uf}{u+f} \Rightarrow v = \frac{-f \times -f}{-f-f} = \frac{f^2}{-2f} = -\frac{f}{2}$$

$$\therefore \text{dist of image from optical centre} = \frac{f}{2}$$

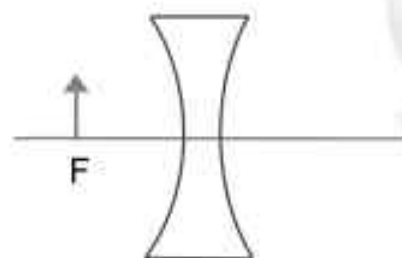

Sol17.  $\frac{dP}{dV} = -aP$ , at  $V = V_0, P = P_0$

$$T_{\max} = ? \text{ for } n = 1$$

$$\frac{dP}{dV} = -aP \quad (\text{Given})$$

$$\frac{dP}{P} = -a dV$$

On integrating, we get

$$\int_{P_0}^P \frac{dP}{P} = -a \int_0^V dV$$

$$\ln\left(\frac{P}{P_0}\right) = -a(V) \Rightarrow P = P_0 e^{-aV}$$

Also, we know,  $PV = nRT$

$$(P_0 e^{-aV})V = nRT$$

$$\Rightarrow T = \frac{P_0 V e^{-aV}}{nR}$$

$$\begin{aligned} \Rightarrow \frac{dT}{dV} &= 0 \quad [\text{for } T_{\max}] \\ \Rightarrow \frac{P_0}{nR} \left[ \frac{d}{dV} \{ V e^{-aV} \} \right] &= 0 \\ \Rightarrow \frac{d}{dV} \{ V e^{-aV} \} &= 0 \\ \Rightarrow V e^{-aV} \times -a + e^{-aV} \cdot 1 &= 0 \\ \Rightarrow (-aV + 1) e^{-aV} &= 0 \\ \Rightarrow V = \frac{1}{a} \text{ or } V = 0 \\ \therefore T_{\max} &= \frac{P_0}{nR} \times \frac{1}{a} \times e \\ &= \frac{P_0}{naR} \times e^{-1} \\ T_{\max} &= \frac{P_0}{aeR} \quad \because n = 1 \end{aligned}$$

**Sol18.**  $\vec{L} = \vec{r} \times \vec{p} \Rightarrow \vec{L} = mvr(\hat{k})$

Direction & magnitude both remain same for particle moving with constant speed.

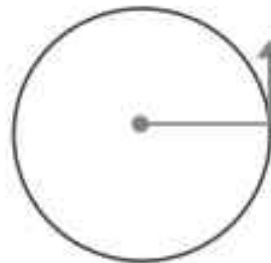

- Sol19.** (a) Torque  $\rightarrow ML^2T^{-2} \rightarrow$  (iii)  
 (b) Impulse  $\rightarrow MIT^{-1} \rightarrow$  (i)  
 (c) Tension  $\rightarrow MLT^{-2} \rightarrow$  (iv)  
 (d) surface Tension  $\rightarrow \frac{MLT^{-2}}{L} = MT^{-2}$  (ii)

**Sol20.** From observation, we can say that right of  $-5\mu\text{c}$  charge, net electric force (or electric field) can be zero.

$$\text{So, } \frac{k(5\mu\text{c})q}{x^2} = \frac{k(20\mu\text{c})q}{(5+x)^2}$$

$$\Rightarrow \frac{1}{x^2} = \frac{4}{(5+x)^2}$$

$$\Rightarrow \left( \frac{5+x}{x} \right)^2 = 2^2$$

$$\Rightarrow \frac{5+x}{x} = 2$$

$$\Rightarrow x = 5\text{cm}$$



## SECTION - B

**Sol1.**  $R_{eq} = 6\Omega$

$\therefore i = \frac{12V}{6\Omega} \Rightarrow 2A$  (through battery)

$\therefore v_{15\Omega} = 6V$

**Sol2.**  $R_{eq} = 3\Omega$



**Sol3.**  $\theta = \frac{60^\circ}{2} = 30^\circ$

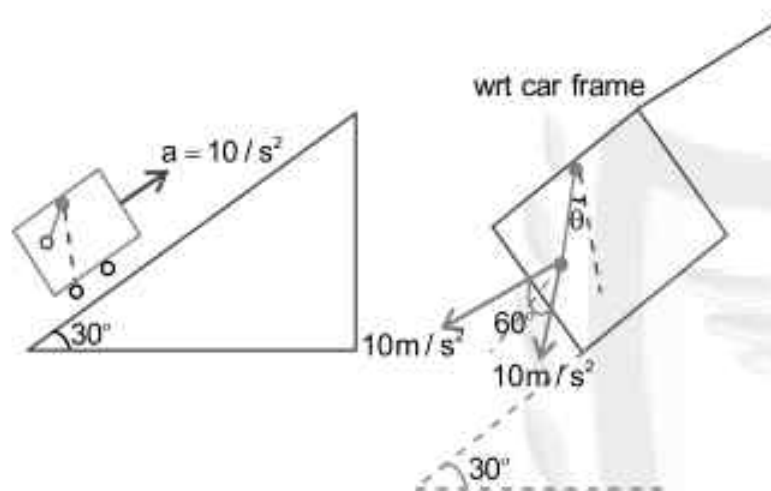

**Sol4.**  $Q = CV$

$= (50 \mu F) \times 2V$

$= 100 \times 10^{-6} C$

$Q = 100\mu C \rightarrow$  (on upper plate)

**Sol5.**  $\mu = 9 \times 10^{-4} kg/m$

$T = 900N$

$f_0 = 500Hz \rightarrow$  resonance frequency

$f_0' = 550Hz \rightarrow$  Next higher frequency

$\therefore \ell = n \frac{\lambda}{2}$  (for wire fixed at both ends)

$v = \sqrt{\frac{T}{\mu}} = \sqrt{\frac{900N}{9 \times 10^{-4}}} = 1000m/s$

$\therefore v = f\lambda$

or  $\frac{v}{\lambda} = f \Rightarrow f_0' = \frac{nv}{2\ell}$

$f' = \frac{(n+1)v}{2\ell}$

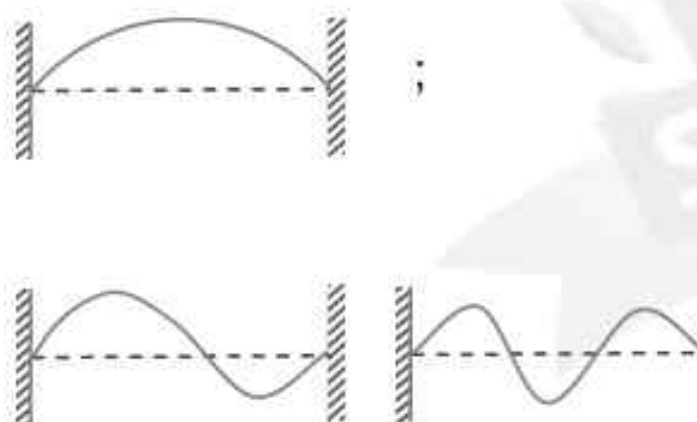

$$\begin{aligned} 500\text{Hz} &= \frac{n \times 1000}{2\ell} \\ 550\text{Hz} &= \frac{(n+1) \times 1000}{2\ell} \end{aligned}$$

$$\frac{10}{11} = \frac{n}{n+1} \Rightarrow n = 10$$

$$\therefore 500\text{Hz} = \frac{10 \times 1000}{2 \times \ell}$$

$$\Rightarrow \ell = 10\text{m}$$

Sol6.  $P = -B \left( \frac{\Delta v}{v} \right)$

or  $B = \frac{-P}{\left( \frac{\Delta v}{v} \right)}$

$$B = \frac{-(\rho gh)}{\left( \frac{-0.5\% \text{ of } V_0}{V_0} \right)}$$

$$B = \frac{-\rho gh}{\left( \frac{-0.005 V_0}{V_0} \right)} \Rightarrow h = \frac{908 \times 10^8 \times 0.005}{10^3 \times 9.8}$$

$$\Rightarrow h = 500\text{m}$$

Sol7.  $x = A \sin \omega t$  (Eq. of a particle executing SHM)

When KE = PE

$$\frac{1}{2}mv^2 = \frac{1}{2}kx^2$$

$$\frac{1}{2}m\omega^2(A^2 - x^2) = \frac{1}{2}kx^2 \quad [\because k = m\omega^2]$$

$$A^2 - x^2 = x^2$$

$$x = \pm \frac{A}{\sqrt{2}}$$

at equilibrium

$$x_0 = \frac{mg}{k}$$

So,  $\frac{A}{\sqrt{2}} = A \sin \omega t$

$$\frac{1}{\sqrt{2}} = \sin \omega t$$

$$\frac{\pi}{4} = \omega t$$

$$\frac{\pi}{4\omega} = t \text{ \& } T = \frac{2\pi}{\omega}$$

$$\therefore t = \frac{T}{8}$$

**Sol8.**  $\therefore \frac{P_i}{m \times 40} = \frac{P_f}{2} = \frac{m}{2} v' + \frac{m}{2} \times 60$   
 $\Rightarrow v' = 20 \text{ m/s}$   
 $kE_i = \frac{1}{2} m \left[ v^2 + 60^2 \right]$   
 $= \frac{1}{2} m (20^2 + 60^2)$   
 $= \frac{1}{2} m (2000)$   
 $\frac{\Delta KE}{KE} = \frac{\frac{1}{2} m (2000) - \frac{1}{2} m (1600)}{\frac{1}{2} m (1600)}$   
 $= \frac{\frac{1}{2} m (400)}{\frac{1}{2} m (1600)} = \frac{1}{4} = \frac{x}{4}$   
 $\therefore x = 1$

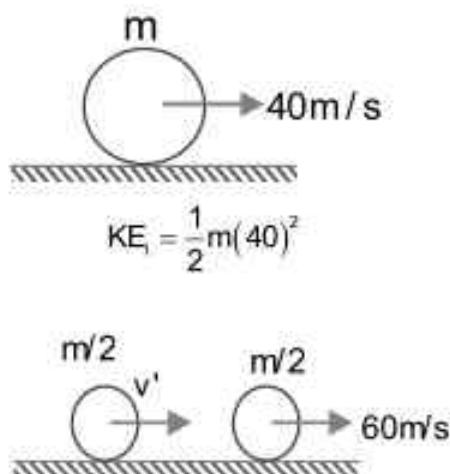

**Sol9.**  $E = (50 \text{ N/s}) \sin \omega(t - x/c)$   
 Energy  $5.5 \times 10^{-12} \text{ J}$ , vol  $v = ?$   
 $u = \frac{1}{2} \epsilon_0 E^2 \rightarrow$  energy density  
 $\therefore u = \frac{U}{v} \Rightarrow U = uv$   
 $= \frac{1}{2} \epsilon_0 E^2 \cdot v$   
 $5.5 \times 10^{-12} = \frac{1}{2} \times 8.85 \times 10^{-12} \times 50^2 \times v$   
 $v = \frac{5.5 \times 10^{-12} \times 2}{8.85 \times 2500 \times 10^{-12}} \times 10^6 \text{ cm}^3$   
 $= 0.0497 \times 10^6$   
 $= 497$   
 $\cong 500 \text{ cm}^3$

**Sol10.**  $dM = \sqrt{2Rh_T} + \sqrt{2Rh_R}$   
 $\therefore h_T + h_R = 160$  [ Given ]  
 So,  $h_R = 160 - h_T$   
 $d_M = \sqrt{2Rh_T} + \sqrt{2R(160 - h_T)}$   
 $\therefore \frac{d(dM)}{dh_T} = 0$  [for maxima / minima]  
 $\Rightarrow 0 = \frac{1}{2\sqrt{2Rh_T}} + \frac{1}{2\sqrt{2R(160 - h_T)}} \times -1$   
 $\Rightarrow \frac{1}{2\sqrt{2Rh_T}} = \frac{1}{2\sqrt{2R(160 - h_T)}}$



**Sol7.** Portland cement contains  
 Dicalcium silicate = 26%  
 Tricalcium silicate = 51%  
 Tricalcium aluminate = 11%  
 Hence major percentage is of tricalcium silicate.

**Sol8.** Biuret is

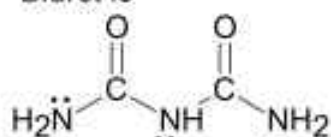

Denticity is 2 of terminal  $-\text{NH}_2$  only, because middle  $-\text{NH}$  will undergo in cross conjugation.

**Sol9.** B.O.D value  $< 5$  ppm for clean water and B.O.D value of polluted water  $\geq 17$  ppm.

**Sol10.** Compound react with  $\text{S}_\text{N}^1$  mechanism in presence of polar protic solvent, which follows carbocation forming path.  
 Hence correct order is.

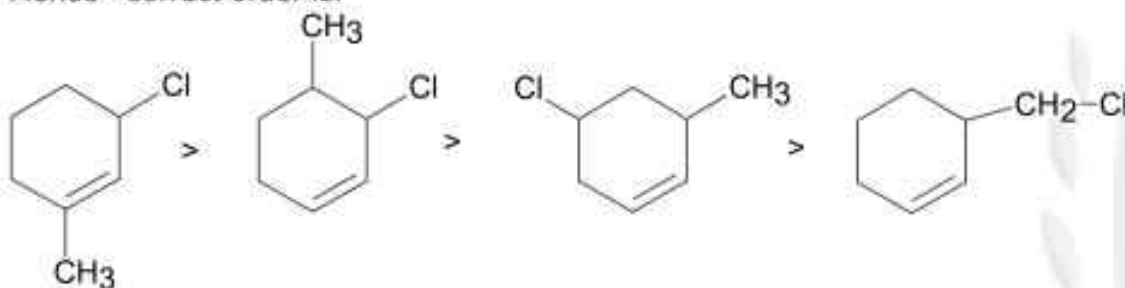

**Sol11.**

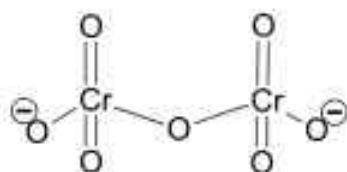

Non-linear and symmetrical Cr-O-Cr bond due to resonance.

**Sol12.**  $\text{La}^{+2}$  ( $z = 57$ ) =  $5d^1$   
 $\text{Ce}^{+2}$  ( $z = 58$ ) =  $4f^2$   
 $\text{Nd}^{+2}$  ( $z = 60$ ) =  $4f^4$   
 $\text{Yb}^{+2}$  ( $z = 70$ ) =  $4f^{14}$

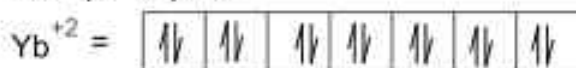

$\text{Yb}^{+2}$  has no unpaired electrons thus diamagnetic in nature.

**Sol13.** Simple distillation can be applied for the separation of two liquids has boiling point difference greater than  $20^\circ\text{C}$ .  
 Boiling point of propanol  $>$  boiling point of propanone (due to H-bonding effect)

**Sol14.** Novolac is linear polymer of o-hydroxymethylphenol.

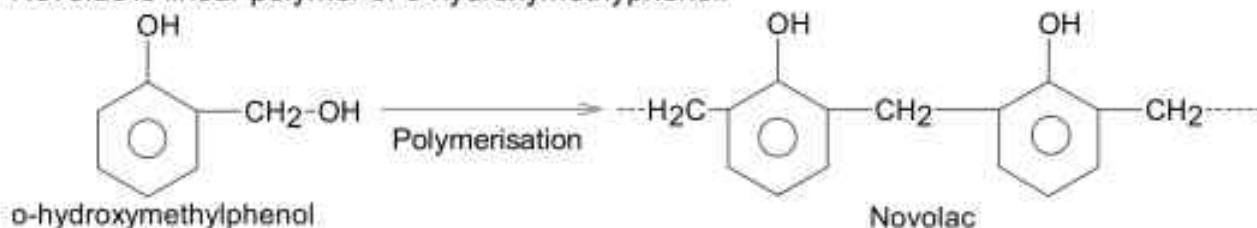

Sol15.

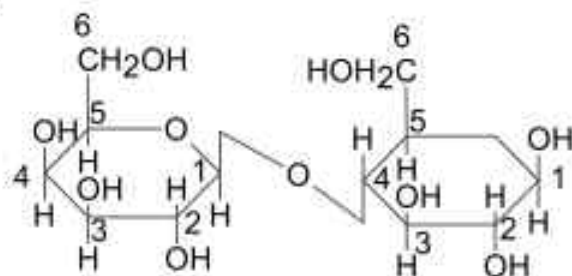

Lactose is polymer contain glycosidic linkage between C<sub>1</sub> of β- galactose & C<sub>4</sub> of β- glucose.

Sol16.

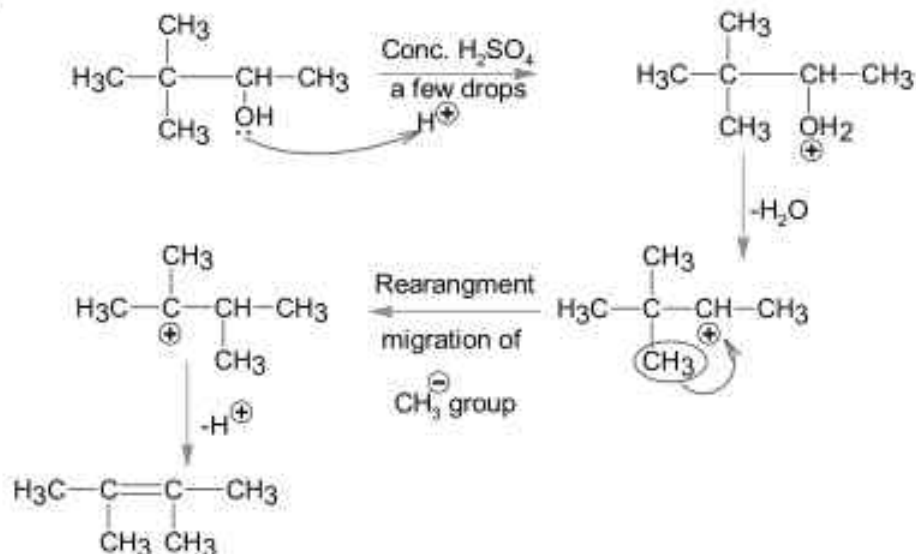

Sol17.  $\Delta T_f = iK_f m$

Higher the value of  $i$ , more be  $\Delta T_f$ .

- Glucose  $\rightarrow i = 1$
- Hydrazine  $\rightarrow i = 1$
- Glycine  $\rightarrow i = 1$
- KHSO<sub>4</sub>  $\rightarrow i = 3$  ( $K^+ H^+ SO_4^-$ )

Sol18.

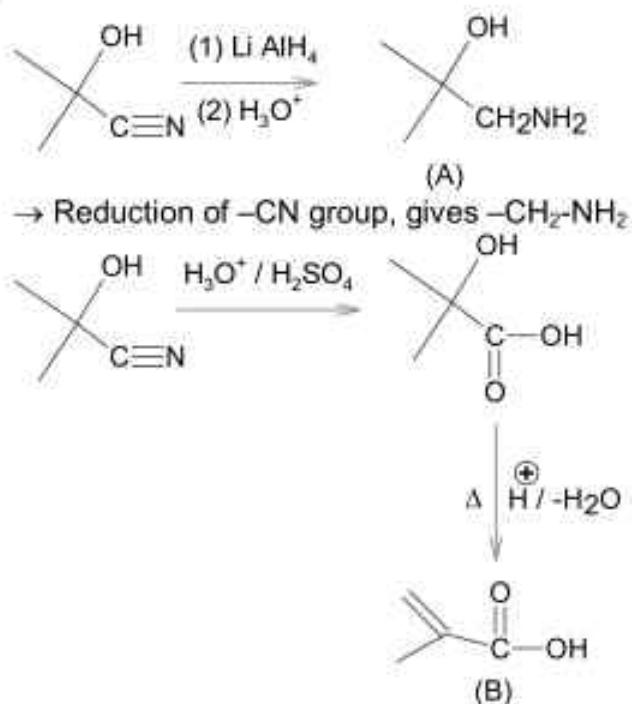

Sol19.  $PV = nRT$        $PV = \text{constant}$  (at constant T)

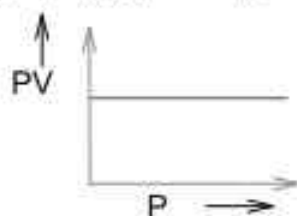

Pressure increases & volume decreases, PV remains constant at constant T.

Sol20.

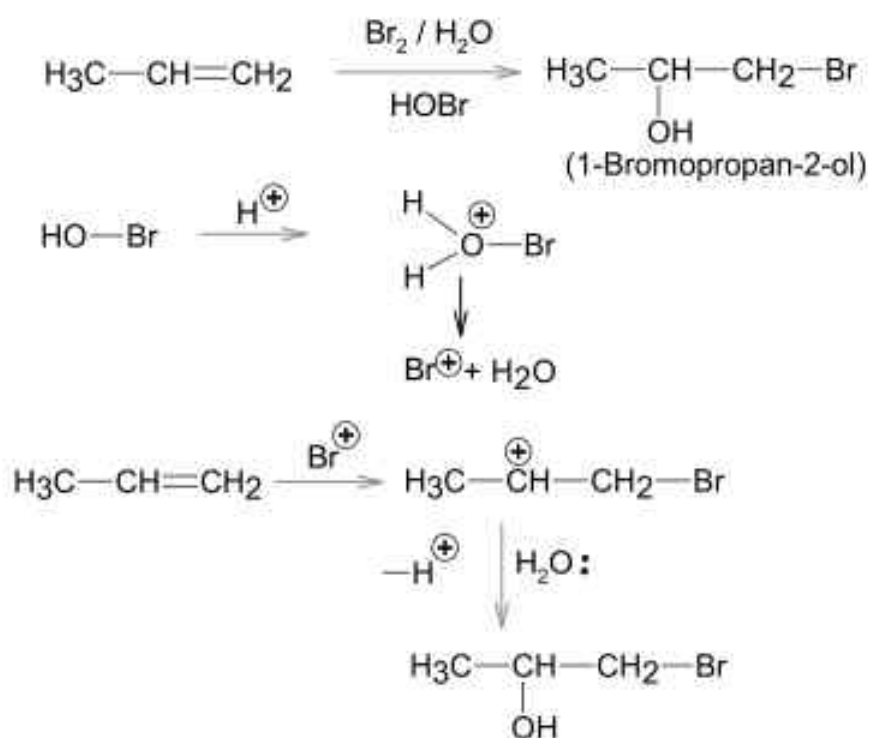

### SECTION - B

Sol1.



$$\therefore K_{\text{sp}} = [\text{A}^{+2}]^3 [\text{B}^{3-}]^2$$

$$= \left(\frac{3x}{M}\right)^3 \left(\frac{2x}{M}\right)^2$$

$$= 27 \left(\frac{x}{M}\right)^3 \times 4 \left(\frac{x}{M}\right)^2$$

$$= 108 \left(\frac{x}{M}\right)^5$$

$$K_{\text{sp}} = a \left(\frac{x}{M}\right)^5 = 108 \left(\frac{x}{M}\right)^5$$

Ans.  $\therefore a = 108$

Sol2.

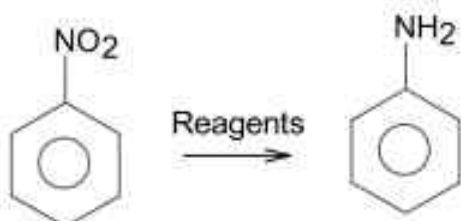

Reagents can be used are  $\Rightarrow$

- (1) Sn / HCl
- (2) Fe / HCl
- (3) H<sub>2</sub> / Pd
- (4) H<sub>2</sub> / Raney Ni
- (5) Zn / HCl

Ans. = 5

Sol3. Molarity (M) =  $\frac{w \times 1000}{\text{molecular mass} \times \text{volume of solution (ml)}}$

$$= \frac{6.3 \times 1000}{126 \times 250} = \frac{4}{20} = 0.2M$$

Molecular mass of oxalic acid (H<sub>2</sub>C<sub>2</sub>O<sub>4</sub>·2H<sub>2</sub>O)

$$= 1 \times 2 + 12 \times 2 + 16 \times 4 + 2 \times 18$$

$$= 26 + 64 + 36 = 126$$

$$M = 2 \times 10^{-1}M$$

$$= 20 \times 10^{-2}M$$

$$\therefore x \times 10^{-2} = 20 \times 10^{-2}$$

$$\therefore x = 20$$

Ans. = 20

Sol4.

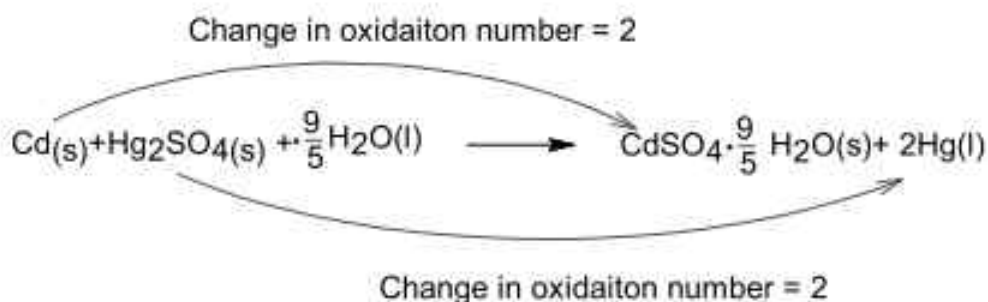

$$\therefore n = 2$$

$$\Delta G^\circ = -nE_{\text{cell}}^\circ F$$

$$= -2 \times 4.315 \times 96487 \text{ Jmol}^{-1}$$

$$\therefore \Delta G^\circ = \Delta H^\circ - T\Delta S^\circ$$

$$\Delta S^\circ = \frac{\Delta H^\circ - \Delta G^\circ}{T}$$

$$= \frac{-825.2 \times 1000 - (-2 \times 4.315 \times 96487)}{298.15} \text{ JK}^{-1}$$

$$\Delta S^\circ = \frac{2 \times 4.315 \times 96487 - 825.2 \times 1000}{298.15} \text{ JK}^{-1}$$

$$= \frac{832682.81 - 825200}{298.15} \text{ JK}^{-1}$$

$$= \frac{7482.81}{298.15} = 25.09 \text{ JK}^{-1}$$

$$\approx 25.1\text{JK}^{-1}$$

Ans. = 25

- Sol5.** HgS, PbS, CuS, Sb<sub>2</sub>S<sub>3</sub>, As<sub>2</sub>S<sub>3</sub>, & CdS are given sulphides  
CdS, PbS, As<sub>2</sub>S<sub>3</sub> & CuS are soluble in 50% HNO<sub>3</sub> but Sb<sub>2</sub>S<sub>3</sub> & HgS are not soluble.  
Ans. = 4

**Sol6.**

$$t_{75\%} = \frac{2.303}{K} \log\left(\frac{C_0}{C_0/4}\right) = \frac{2 \times 2.303}{k} \log 2$$

$$t_{50\%} = \frac{2.303}{K} \log\left(\frac{C_0}{C_0/2}\right) = \frac{2.303}{K} \log 2$$

$$\therefore \frac{t_{75\%}}{t_{50\%}} = 2$$

Ans. = 2

- Sol7.**  $\Delta H = (E_{act})_f - (E_{act})_b$   
=  $x - (x + y) = -y$   
=  $-45\text{KJ/mol}$

Ans. = 45

- Sol8.** Cl, Br & I form halic(V) acid i.e HClO<sub>3</sub>, HBrO<sub>3</sub> & HIO<sub>3</sub>.

**Sol9.**

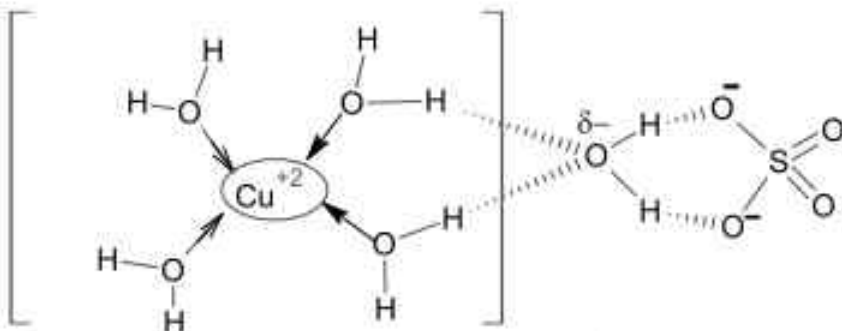

One water molecule is associated with hydrogen bond.

Ans. = 1

- Sol10.** Ge (Z = 32)  
=  $1s^2 2s^2 2p^6 3s^2 3p^6 4s^2 3d^{10} 4p^2$   
 $m_l = 0$  (for 4s, 3s, 2s, 1s) 4 orbital  
 $m_l = 0$  (one p orbital of 2p and 3p)  
 $m_l = 0$  (one d orbital)

Total orbitals = 7

Ans. = 7

## PART – C (MATHEMATICS)

### SECTION - A

**Sol1.**  $(p \wedge \neg q) \rightarrow (p \vee q)$  is tautology

p	q	$\neg q$	$p \wedge \neg q$	$p \vee q$	$(p \wedge \neg q) \rightarrow (p \vee q)$
T	T	F	F	T	T
T	F	T	T	T	T
F	T	F	F	T	T
F	F	T	F	F	T

\* =  $\wedge$ ,  $\square = \vee$

**Sol2.** Equation of plane is  $3x - 2y + 4z - 7 + \lambda (x + 5y - 2z + 9) = 0$  .....(i)

It passes through  $(1, 4, -3)$  and we get  $\lambda = \frac{2}{3}$

$\therefore$  from (i) we get  $11x + 4y + 8z - 3 = 0 \Rightarrow -11x - 4y - 8z + 3 = 0$

$\therefore \alpha + \beta + \lambda = -11 - 4 - 8 = -23$

**Sol3.**  $e^{4x} + 2e^{3x} - e^x - 6 = 0$

$e^x = t \in (0, \infty)$

$t^4 + 2t^3 - t - 6 = 0$

Let  $f(t) = t^4 + 2t^3 - t - 6$

$f'(t) = 4t^3 + 6t^2 - 1$

$\Rightarrow f'(0) = -1, f'(+\infty) = +\infty$

$f''(t) = 12t^2 + 12t = 12t(t+1) > 0$

For  $t > 0$

$\Rightarrow f'(t) = 0$  has only one root.

One solution of  $f(t) = 0$  is possible

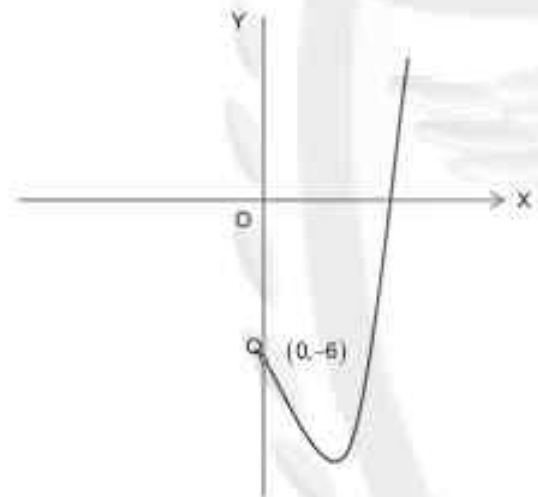

**Sol4.**  $f(x) = |x^2 - 2x - 3|e^{(3x^2 - 12x + 4)}$

$$\Rightarrow f(x) = \begin{cases} (x^2 - 2x - 3)e^{(3x-2)^2}, & x < -1 \\ -(x^2 - 2x - 3)e^{(3x-2)^2}, & -1 \leq x < 3 \\ (x^2 - 2x - 3)e^{(3x-2)^2}, & x \geq 3 \end{cases}$$

$$f'(x) = \begin{cases} 2e^{(3x-2)^2} \left( (x-1) + 3(x^2 - 2x - 3)(3x-2) \right), & x < -1, x > 3 \\ -2e^{(3x-2)^2} \left( (x-1) + 3(x^2 - 2x - 3)(3x-2) \right), & -1 < x < 3 \end{cases}$$

$$f'(-1^-) \neq f'(-1^+)$$

$$f'(3^-) \neq f'(3^+)$$

Number of non differential points is 2 at  $x = -1, 3$ .

**Sol5.** Length of perpendicular from origin to  $x \operatorname{cosec} \alpha - y \sec \alpha = k \cot 2\alpha$  and  $x \sin \alpha + y \cos \alpha = k \sin 2\alpha$  are

$$p = k \cot 2\alpha \sin \alpha \cos \alpha = \frac{k}{2} \cdot \frac{\cos 2\alpha}{\sin 2\alpha} \sin 2\alpha = \frac{k}{2} \cos 2\alpha \Rightarrow \frac{2p}{k} = \cos 2\alpha$$

$$\text{and } q = k \sin 2\alpha \Rightarrow \frac{q}{k} = \sin 2\alpha$$

on solving these two we get  $4p^2 + q^2 = k^2$

**Sol6.** 
$$\lim_{x \rightarrow 0} \frac{\sin^2(\pi \cos^4 x)}{x^4} = \lim_{x \rightarrow 0} \frac{\sin^2(\pi - \pi \cos^4 x)}{x^4} = \lim_{x \rightarrow 0} \frac{\sin^2(\pi \sin^2 x(1 + \cos^2 x))}{x^4}$$

$$= \lim_{x \rightarrow 0} \frac{\sin^2(\pi \sin^2 x(1 + \cos^2 x))}{\pi^2 \sin^4 x(1 + \cos^2 x)^2} \times \frac{\pi^2 \sin^4 x(1 + \cos^2 x)^2}{x^4} = 4\pi^2 \lim_{x \rightarrow 0} \frac{\sin^4 x}{x^4} = 4\pi^2$$

**Sol7.**  $\therefore a_r = e^{\frac{2r\pi}{9}}$

$\therefore a_1, a_2, a_3, \dots$  are in G.P.

$$\begin{vmatrix} a_1 & a_1 r & a_1 r^2 \\ a_1 r^3 & a_1 r^4 & a_1 r^5 \\ a_1 r^6 & a_1 r^7 & a_1 r^8 \end{vmatrix} = a_1^3 r^9 \begin{vmatrix} 1 & r & r^2 \\ 1 & r & r^2 \\ 1 & r & r^2 \end{vmatrix} = 0$$

(i)  $a_2 a_6 - a_4 a_8 = a_1 r a_1 r^5 - a_1 r^3 a_1 r^7 = a_1^2 r^3 - a_1^2 r^{10} \neq 0$

(ii)  $a_9 = a_1 r^8 \neq 0$

(iii)  $a_1 a_1 r^8 - a_1 r^2 a_1 r^6 = 0$

(iv)  $a_5 \neq 0$

**Sol8.** Length of latus rectum = 4(distance between vertex and focus) = 4(S - R)

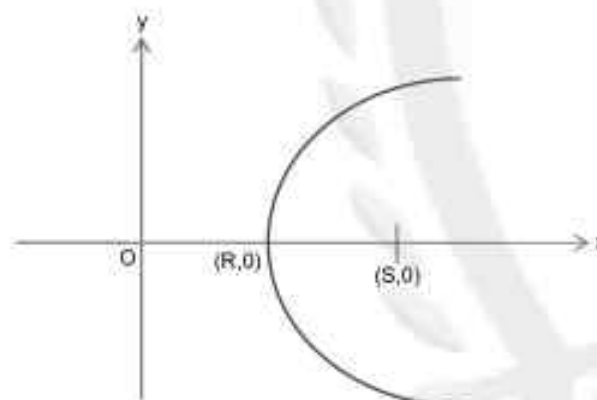

**Sol9.** Let  $\therefore \frac{a}{r}, a, ar$  are in G.P.  $\therefore \frac{a}{r}, 2a, ar$  are in A.P.

$$2a - \frac{a}{r} = ar - 2a \Rightarrow 2 - \frac{1}{r} = r - 2 \Rightarrow r^2 - 4r + 1 = 0 \Rightarrow r = 2 + \sqrt{3}$$

A/q,  $ar^2 = 3r^2 \Rightarrow a = 3$

$\therefore d = ar - 2a = 3\sqrt{3}$

$\therefore r^2 - d = 7 + \sqrt{3}$

**Sol10.** Since the line  $\frac{x}{5} \cos \theta + \frac{y}{12} \sin \theta = 1$  is the equation of tangent to the ellipse  $\frac{x^2}{5^2} + \frac{y^2}{12^2} = 1$  at  $(5 \cos \theta, 12 \sin \theta)$ . Hence option (A) is correct option.

Sol11. LHS =  $\lim_{x \rightarrow 0^-} f(x) = \lim_{h \rightarrow 0} \frac{-1}{h} \ln \left( \frac{1 - \frac{h}{a}}{1 + \frac{h}{b}} \right) = \lim_{h \rightarrow 0} \frac{\ln \left( 1 - \frac{h}{a} \right)}{a \left( \frac{-h}{a} \right)} + \lim_{h \rightarrow 0} \frac{\ln \left( 1 + \frac{h}{b} \right)}{b \left( \frac{h}{b} \right)} = \frac{1}{a} + \frac{1}{b}$  .....(i)

RHS =  $\lim_{x \rightarrow 0^+} f(x) = \lim_{x \rightarrow 0} \frac{\cos 2x - 1}{x^2 + 1 - 1} (\sqrt{x^2 + 1} + 1) = \lim_{x \rightarrow 0} \frac{-2 \sin^2 x}{x^2} \times 2 = -4$  .....(ii)

and  $\lim_{x \rightarrow 0} f(x) = k$  .....(iii)

$f(0^-) = f(0^+) = f(0)$

$\Rightarrow \frac{1}{a} + \frac{1}{b} = -4 = k$

From (i), (ii) and (iii) we get  $\therefore \frac{1}{a} + \frac{1}{b} + \frac{4}{k} = k + \frac{4}{k} = -4 - 1 = -5$

Sol12.  $\int \frac{dx}{\left(\frac{x-1}{x+2}\right)^{3/4} (x+2)^{3/4} (x+2)^{5/4}} = \int \frac{dx}{\left(\frac{x-1}{x+2}\right)^{3/4} (x+2)^2}$  put  $\frac{x-1}{x+2} = t \Rightarrow \frac{3}{(x+2)^2} dx = dt$

$\therefore \frac{1}{3} \int \frac{dt}{t^{3/4}} = \frac{1}{3} \cdot \frac{t^{1/4}}{1/4} + C = \frac{4}{3} \left(\frac{x-1}{x+2}\right)^{1/4} + C$

Sol13.  $\therefore \frac{3}{1^2 \times 2^2} + \frac{5}{2^2 \times 3^2} + \frac{7}{3^2 \times 4^2} + \dots$

$\therefore t_r = \frac{2r+1}{r^2(r+1)^2} = \frac{1}{r^2} - \frac{1}{(r+1)^2}$

$S_{10} = \sum_{r=1}^{10} t_r = \sum_{r=1}^{10} \left( \frac{1}{r^2} - \frac{1}{(r+1)^2} \right) = 1 - \frac{1}{11^2} = \frac{120}{121}$

Sol14.  $0 < |x-y| \leq 1 \Leftrightarrow 0 < |y-x| \leq 1$

but  $0 < |x-y| \leq 1$  and  $0 < |y-z| \leq 1$  does not necessarily imply that  $0 < |x-z| \leq 1$

as  $0 < |x-y| \leq 1 \Rightarrow -1 < x-y \leq 1$  with  $x \neq y$  .....(i)

and  $0 < |y-z| \leq 1 \Rightarrow -1 \leq y-z \leq 1$  with  $y \neq z$  .....(ii)

(i) + (ii)  $\Rightarrow -2 \leq x-z \leq 2$

For example (1,2) and (2,3) satisfy  $0 < |x-y| \leq 1$  but (1,3) does not satisfy it.

$0 < |x-y| \leq 1$  is symmetric and but not transitive.

Option (D) is correct option.

Sol15.  $\frac{dy}{dx} = \frac{2^{x \cdot y} - 2^x}{2^y} \Rightarrow \int \frac{2^y dy}{2^y - 1} = \int 2^x dx \Rightarrow \text{put } 2^y - 1 = t \Rightarrow 2^y \ln 2 dy = dt$

$\frac{1}{\ln 2} \int \frac{dt}{t} = \int 2^x dx \Rightarrow \frac{1}{\ln 2} \ln t = \frac{2^x}{\ln 2} + \frac{C}{\ln 2}$  put  $x = 0$  and  $y = 1$  we get  $C = -1$

$\therefore \ln(2^y - 1) = 2^x - 1$  put  $x = 1$  and we get  $y = \log_2(1 + e)$

**Sol16.** Applying Leibniz theorem ,

$$\sqrt{1-(f'(x))^2} = f(x) \Rightarrow \frac{f'(x)}{\sqrt{1-(f(x))^2}} = 1 \text{ on integrating both sides , we get}$$

$$f(x) = \sin x + C \text{ put } x = 0 \text{ and } f(0) = 0 \text{ we get } C = 0$$

$$\text{Now } \lim_{x \rightarrow 0} \frac{\int_0^x f(t) dt}{x^2} = \left(\frac{0}{0}\right) \text{ by L'Hospital rule } \lim_{x \rightarrow 0} \frac{f(x)}{2x} = \lim_{x \rightarrow 0} \frac{\sin x}{2x} = \frac{1}{2}$$

**Sol17.**  $|2\vec{a} + 3\vec{b}|^2 = |3\vec{a} + \vec{b}|^2 \Rightarrow 4|\vec{a}|^2 + 9|\vec{b}|^2 + 12\vec{a}\cdot\vec{b} = 9|\vec{a}|^2 + |\vec{b}|^2 + 6\vec{a}\cdot\vec{b}$

$$\Rightarrow -5|\vec{a}|^2 + 8|\vec{b}|^2 + 6\vec{a}\cdot\vec{b} = 0 \dots\dots\dots(i)$$

$$\cos 60^\circ = \frac{\vec{a}\cdot\vec{b}}{|\vec{a}||\vec{b}|} = \frac{1}{2} \therefore \vec{a}\cdot\vec{b} = 4|\vec{b}| \text{ and } |\vec{a}| = 8$$

from (i) we get  $|\vec{b}| = 5$

**Sol18.**  $\theta = 18^\circ \Rightarrow 2\theta + 3\theta = 90^\circ \Rightarrow \sin 3\theta = 1 - \sin 2\theta \Rightarrow \cos \theta (4 \sin^2 \theta + 2 \sin \theta - 1) = 0$

$$\because \cos \theta \neq 0 \therefore 4 \sin^2 \theta + 2 \sin \theta - 1 = 0 \Rightarrow \operatorname{cosec}^2 18^\circ - 2 \operatorname{cosec} 18^\circ - 4 = 0$$

$$\Rightarrow x^2 - 2x - 4 = 0$$

**Sol19.**  $\tan \theta = \frac{3x}{18} = \frac{x}{6} \dots\dots(i)$  and

$$\tan 2\theta = \frac{10x}{18} = \frac{5x}{9} \dots\dots(ii)$$

Solving (i) and (ii)  $\frac{2 \tan \theta}{1 - \tan^2 \theta} = \frac{5x}{9}$  we get  $x = \sqrt{\frac{72}{5}}$

Height of pole =  $10x = 12\sqrt{10}$

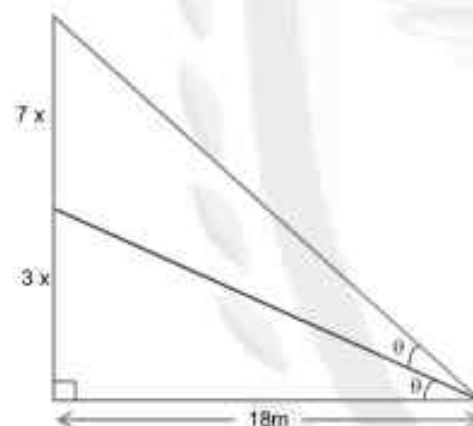

**Sol20.**  $\Delta = \begin{vmatrix} 2 & 1 & 1 \\ 1 & -1 & 1 \\ 1 & 1 & a \end{vmatrix} = 2(-a-1) + (1-a) + 2 = -3a + 1$

$$\Delta_3 = \begin{vmatrix} 2 & 1 & 5 \\ 1 & -1 & 3 \\ 1 & 1 & b \end{vmatrix} = 2(-b-1) + (3-b) + 5 \times 2 = -3b + 7$$

For  $a = \frac{1}{3}$ ,  $b \neq \frac{7}{3}$ , system has no solution

### SECTION - B

**Sol1.**  $f(x) = x^2 + ax + 1 \Rightarrow f'(x) = 2x + a$

for increasing  $f'(x) \geq 0$

$$\therefore 2x + a \geq 0 \Rightarrow a \geq -2x \Rightarrow a \geq -2 \times 2 \Rightarrow a \geq -4 \therefore R = -4$$

And for decreasing  $f'(x) \leq 0 \Rightarrow a \leq -2x \Rightarrow a \leq -2 \times 1 \therefore S = -2$

$$|R - S| = 2$$

**Sol2.**  $I = \int_{-1/2}^1 [2x]dx + \int_{-1/2}^1 |2x| dx$

Let  $I_1 = \int_{-1/2}^1 [2x]dx$  put  $2x = t \Rightarrow dx = \frac{dt}{2}$

$\therefore I_1 = \frac{1}{2} \int_{-1}^2 [t]dx \Rightarrow I_1 = \frac{1}{2} \left[ \int_{-1}^0 [t]dx + \int_0^1 [t]dx + \int_1^2 [t]dx \right] = 0$

and let  $I_2 = \int_{-1/2}^1 |x| dx = -\int_{-1/2}^0 x dx + \int_0^1 x dx = \frac{5}{8}$

$\therefore I = I_1 + I_2 = 0 + \frac{5}{8} = \frac{5}{8} \Rightarrow 8I = 5$

**Sol3.** Since centres  $C_1(1,1)$  and  $C_2(9,1)$  lies opposite sides of the line  $3x + 4y = \alpha$

$((3+4-\alpha)((27+4-\alpha) < 0 \Rightarrow \alpha \in (7,31) \dots\dots\dots(i)$

Also length of perpendicular from centre of the circle is greater than radius of the circle .

$\frac{|3+4-\alpha|}{5} \geq 1 \Rightarrow \alpha \leq 2 \text{ or } \alpha \geq 12 \dots\dots\dots(ii)$

and  $\frac{|27+4-\alpha|}{5} \geq 2 \Rightarrow \alpha \leq 21 \text{ or } \alpha \geq 41 \dots\dots\dots(iii)$

from (i), (ii) and (iii) we get  $\alpha \in [12,21]$

$\therefore$  sum of all integers = 165.

**Sol4.** VOWELS

vowels – 2 , constants – 4

all the consonants never come together =  $6! - 3!4! = 720 - 144 = 576$

**Sol5.**  $\therefore \frac{x-1}{2} = \frac{y-2}{3} = \frac{z+1}{6} = r$  (say)

Let  $P(1+2r, 2+3r, -1+6r)$  lies on the plane  $2x - y + z = 6 \therefore r = 1 \Rightarrow P(3,5,5)$

Distance between P and Q is  $PQ = \sqrt{16+36+9} = \sqrt{61}$

$\therefore PQ^2 = 61$

**Sol6.**  $\left(\frac{x}{4} - \frac{12}{x^2}\right)^{12}$

General term  $T_{r+1} = {}^{12}C_r \left(\frac{x}{4}\right)^{12-r} \left(-\frac{12}{x^2}\right)^r = {}^{12}C_r \frac{(-12)^r}{4^{r+1}} x^{12-3r}$

According to question ,  $12 - 3r = 0 \Rightarrow r = 4$

$T_5 = {}^{12}C_4 \frac{(-12)^4}{4^{12-4}} = \frac{3^6}{4^4} \times 55$

$\Rightarrow \frac{3^6}{4^4} \times 55 = \frac{3^6}{4^4} \times k \Rightarrow k = 55$

**Sol7.** Let  $z_c$  be the centre of the circle

$$\frac{z_c - 2}{z_c + 2} = i \Rightarrow z_c = 2i$$

Radius of the circle =  $\sqrt{4+4} = 2\sqrt{2}$

Square off minimum distance  $AB = (7\sqrt{2})^2 = 98$

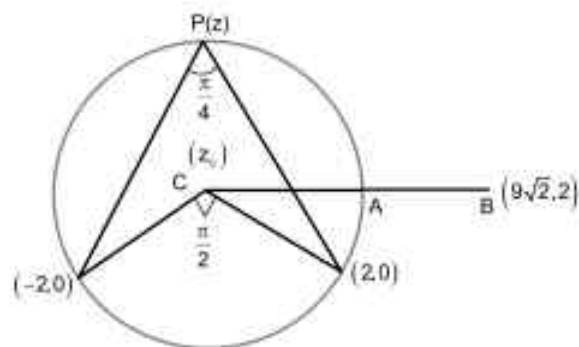

**Sol8.** Let  $t_r = (3r+4)(2r+6) = 6r^2 + 26r + 24$

$$\therefore \sum_{r=1}^{10} t_r = \frac{6 \times 10 \times 11 \times 21}{6} + \frac{26 \times 10 \times 11}{2} + 24 \times 10 = 10 \times 398$$

$$\therefore \text{Mean} = \frac{10 \times 398}{10} = 398$$

**Sol9.**  $P(E_1) = 0.9$ ,  $P(\bar{E}_1) = 0.1$  and  $P(E_2) = 0.8$ ,  $P(\bar{E}_2) = 0.2$

$$\therefore \text{Required probability } P = \frac{0.8 \times 0.1}{0.8 \times 0.1 + 0.2 \times 0.1 + 0.9 \times 0.2} = \frac{0.8}{2.8} = \frac{2}{7}$$

$$\therefore 98P = 28$$

**Sol10.**  $x\phi(x) = \int_5^x (3t^2 - 2\phi'(t)) dt, x > -2$ , By Leibniz theorem

$$\phi(x) + x\phi'(x) = 3x^2 - 2\phi'(x) \Rightarrow \phi'(x) + \frac{\phi(x)}{x+2} = \frac{3x^2}{x+2} \dots\dots\dots(i)$$

$$\therefore \text{I.F.} = e^{\int \frac{dx}{x+2}} = x+2$$

Multiplying (i) by I.F. we get ,

$$\phi(x)(x+2) = x^3 + C \text{ put } x = 0 \text{ and } \phi(x) = 4 \text{ we get } C = 8$$

$$\therefore \phi(x) = \frac{x^3 + 8}{x+2}$$

$$\therefore \phi(2) = 4$$